

DC1100 Energy Controller

INSTALLATION, WIRING AND COMMISSIONING INFORMATION FOR SELF CONFIGURING OPTIMISER/COMPENSATOR WITH BOILER SEQUENCE AND HWS CONTROL

INTRODUCTION

DC1100

The DC1100 is a stand-alone direct digital controller, which is designed to suit the control needs of smaller commercial and larger domestic properties.

It will control one or two boilers, with requirements for optimum start and with direct or valve compensation.

A separate channel is provided for the control of hot water.

Each of the control routines can be used independently or combined. In effect the unit can be a compensator, an optimiser or a combined unit.

Easy installation and operation are key features of the DC1100. At the base level, the unit can be reset after the sensors have been connected and the unit will configure itself to the intended application. The use of default settings means that the system can be set to control by simply setting the required temperature and occupation times. The self-adapting features adjust the operation to the building.

A front panel switch allows you to override the unit without the need to change any settings. If manual setting of the unit is required, adjustments can be made with visual help from the 4 line display.

LEDs provide an immediate visual indication of output status.

DC1100C

The DC1100C is only available as a replacement for an existing DC1100C controller.

This optional model allows a building to be economically and simply monitored remotely for maintenance and energy management purposes.

Using the well established DC COMMS Estate Management software used by the DC2100C controller, this product can be incorporated into an existing system where this software is already installed.

When the DC1100C is connected by a telephone network and modems, access to the current performance of the heating system can be achieved. Historical records of temperature are taken at regular intervals and, perhaps most importantly, alarm information is available so that corrective measures can be taken with minimum delay, perhaps in the event of the boiler failing to fire in the morning. Full access to the controller settings allows alterations to be made via the modem link.

CONTENTS

INTRODUCTION	1
INPUTS	2
OUTPUTS	2
DESCRIPTION OF OPERATION	2
INSTALLATION	4
WIRING	4
COMMISSIONING	5
DC1100 SYSTEM PARAMETERS	6
DC1100 SENSOR RESISTANCE CHART	9
DC1100 SYSTEM MENU	10
FRONT PANEL SWITCH	12
CHANGING AND VIEWING SETTINGS	12
DISPLAY	13
DC1100 CONNECTION DIAGRAM	13
APPLICATION DETAIL	14
SCHEME A	14
SCHEME B	15
SCHEME C	16
SCHEME D	17
SCHEME E	18
SCHEME F	19
SCHEME G	20
SCHEME H	21
SCHEME I	22
HOT WATER APPLICATIONS	23
SCHEME K	23
SCHEME L	23
SCHEME M	24
OUTSIDE AIR SENSORS SHARED BETWEEN CONTROLLERS	24
VALVE ACTUATOR OUTPUTS FOR 24V ACTUATOR	24
REMOTE SWITCH UNIT DETAIL	25
ALTERNATIVE SIMPLIFIED REMOTE INTERFACE	25
MAINTENANCE	26
SENSOR TYPES	26
DIMENSION DIAGRAMS	28

INPUTS

Six temperature sensor inputs are available and if connected are used as follows:

Outside Air Temperature

- Optimum Start/Stop
- Day economy
- Compensation
- Frost protection
- Sharing of temperature between units

Compensator Flow Sensor

- Valve compensation
- Compensator low temperature

Boiler Return Sensor

- Frost protection

Boiler Flow Sensor

- One or two boiler control
- Boiler compensation
- Boiler high temperature alarm and cut out
- Low temperature alarm for boiler or pump failure

Space Sensors (2 max.)

- Optimum Start/Stop
- Averaging (when 2 used)
- Day economy
- Compensation
- Frost protection

A Digital Input provides a controller override

- A remote switch unit is available to provide the functions of Auto/Summer/Heating On/Holiday

OUTPUTS

All the outputs are 230Vac derived from the controller. They are as follows:

Boiler No. 1

- Control output either direct to boiler or via a relay/contactor

Boiler No. 2

- Control output either direct to boiler or via a relay/contactor

Pump

- Control output either direct to the pump or via a relay/contactor

Valve Open

- To open terminal on 230V reversing actuator (neutral required from controller)

Valve Close

- To close terminal on 230V reversing actuator (neutral required from controller)

Hot Water

- Timed output

COMMUNICATIONS (DC1100C ONLY)

The DC1100C is only available as a replacement for an existing DC1100C controller.

Interface via modem or direct link and 'DCCOMMS' software for:

- Automatic alarms
- Current status of control
- Changing settings
- Temperature histories

DESCRIPTION OF OPERATION

The DC1100 controller contains a number of control routines which operate independently. Some of these functions may be programmed to become inter-linked. It is this which gives the controller its flexibility. The selection and behaviour of a routine is determined by the user settings. At start-up, the values of these settings have been chosen to give a good standard of control immediately. The main routines in the controller are the optimiser, compensator, boiler control and HWS channel. The optimiser and compensator routines are both self-learning, that is, the values of the relevant settings will be altered automatically in order to obtain optimum control. A list of all settings with their default values and ranges is provided on pages 6, 7 and 8.

Optimum Start

The optimum start facility is a self learning routine which will search for the latest time to start in order to achieve the desired *Space Setpoint* at the start of occupation. The performance of the optimiser is continually monitored throughout the preheat period and updated to

ensure an accurate response in all conditions. Three programmable time periods for each day of the week are available.

The optimum start preheat time is limited to a maximum of 5 hours. At optimum start the boiler(s) and heating pump are switched on and the controller enters a boost mode. If two boilers are being used they are fired at a 10 second interval. If used as an optimiser only then during boost the flow temperature will be limited to the boiler(s) thermostat setting or the *Boiler Flow Setpoint* value, whichever is lowest.

If used as an optimiser/compensator controller, the flow temperature will be limited to the *Compensated Flow High* value. The boost mode will continue until the required space temperature is achieved. The self-learning process of the optimiser will be inhibited if the controller is in an alarm mode. It is essential that the *Space Setpoint* temperature can be achieved to allow compensation to begin and prevent the self-learning optimum start routine progressively advancing the start time.

Optimum Stop

Optimum stop is a self learning routine that predicts how long before the end of the occupation period the heating can be switched off, whilst ensuring that the space temperature does not drop more than one degree below *Space Setpoint* before the end of occupation. When heating is switched off by optimum stop, pump run-on will commence. If the space temperature drops more than 1 degree below setpoint with more than 30 minutes remaining, the heating will switch back on.

Day Economy

Day economy will allow the system to turn the heating off during an occupation period if the space temperature is at or above the *Space Setpoint* and the outside temperature is within 4 degrees of the *Space Setpoint*. When the heating is switched off by day economy, pump run-on will commence.

If during a day economy period the space temperature drops more than 1 degree below setpoint or the outside temperature is no longer within 4 degrees of the *Space Setpoint* then the heating will switch back on.

Frost Protection

This is a two stage control system. The first stage will bring on the heating pump and open the mixing valve (if connected) if the outside temperature falls below the *Outside Frost* setting. The second stage will bring on the pump and boiler(s) if the space temperature falls below the *Space Frost* setting, with flow temperature being limited to the *Compensated Flow High* value. In addition, if a boiler return sensor is fitted, second stage frost will become operative if the boiler return temperature falls below the *Boiler Return Frost* setting. Both stages have a hysteresis of 1.5 degrees.

Frost protection operates during holidays, summer and when the manual switch is in the frost position. Frost protection can also be made to operate on the hot water output.

Pump Run On

Pump run-on allows for the dissipation of heat from the boiler to the system by allowing the heating pump to continue running after the end of any heating period. Pump run-on will operate at the end of any programmed time period, extended time period, frost period or when the manual switch overrides the heating off. During the run-on period, the compensated mixing valve (if fitted), is fully opened and the pump will run for a user selected period of time. At the end of the run-on period, the valve will be closed to prevent gravity circulation during heating off periods.

The boiler(s) will be switched off for the duration of pump run-on. If not required, pump run-on can be disabled

Boiler Control

Boiler control allows for controlling 1 boiler, or 2 boilers in sequence. If the boiler flow sensor is not connected, the boiler(s) will be controlled by it's own thermostats.

SINGLE BOILER TEMPERATURE CONTROL

Single boiler control will maintain the boiler flow temperature at the *Boiler Flow Setpoint* with a time and temperature hysteresis which prevents unnecessary cycling of the boiler.

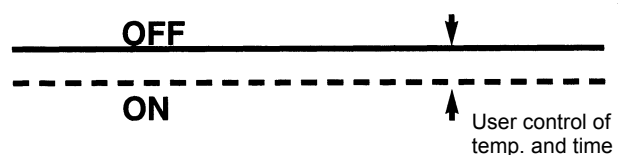

When setpoint is reached, the boiler will be switched off until the *Time Hysteresis* has elapsed and the *Temperature Hysteresis* has occurred. It will then be switched back on.

(The boiler setpoint will be replaced by the compensator calculated setpoint if using direct boiler compensation or the compensator calculated flow setpoint plus the schedule differential if using boiler/valve compensation.)

TWO BOILER SEQUENCE CONTROL

Two boiler control will ensure that both boilers are started at optimum start time with a ten second interval. The boilers will be controlled around the boiler flow setpoint and within a +/- 2 degree band known as the dead band.

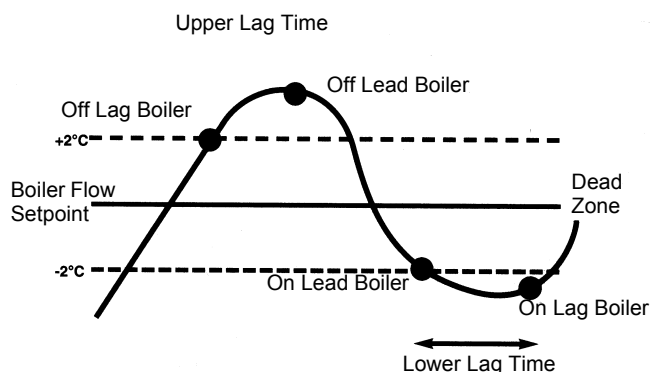

(The boiler setpoint will be replaced by the compensator calculated setpoint if using direct boiler compensation, or the compensator calculated flow setpoint plus the schedule differential if using boiler/valve compensation.)

The second boiler fired in the sequence is switched off when the +2 degree band is exceeded at which time the *Upper Lag Time* delay is started. If when the time delay has elapsed, the boiler flow temperature has not dropped into the dead band, the lead boiler is switched off. If the boiler flow temperature drops below the -2 degree band, the lead boiler in the sequence is switched on at which time a *Lower Lag Time* delay is started. If when the time lag has elapsed the temperature has not risen into the dead band, the second boiler is switched on.

Boilers can be automatically rotated on a weekly basis to even out usage and wear. Rotation will occur at midnight each Sunday. Alternatively, rotation can be disabled in order to maximise the usage of the lead boiler, being particularly useful if it is a condensing boiler. A boiler low alarm indication is provided which is triggered if the boiler flow temperature has failed to reach the *Boiler Low* limit value 60 minutes after optimum start. A boiler high alarm indication is also provided. When the flow temperature exceeds the *Boiler High* limit value, the boilers are switched off. A hysteresis of 2 degrees operates before allowing the boiler(s) to restart. At a further 10 degrees above the *Boiler High* value, the alarm LED will illuminate.

Compensation

The compensator operates on the basis of a straight line relationship between the outside temperature and the required flow temperature to produce a calculated flow setpoint. Without a space sensor fitted, the compensator will work to this fixed slope only. If a space sensor is used, the compensator can be made self adaptive whereby the space temperature provides feedback to continually adjust the slope to suit the building and system characteristics. A space reset facility allows for correction of short term heat gain by depressing the slope by an adjustable factor for each 1 degree that *Space Setpoint* is exceeded. The resultant calculated flow setpoint is used to provide compensated control by valve compensation, boiler compensation or combined valve/boiler compensation. The compensator may be used in conjunction with the optimiser (combined system), or on its own, where the programmed heating times then become fixed time start/stops.

Valve Compensation

Control of the flow temperature will be achieved by modulating the mixing valve. During the optimum start boost period, the flow temperature is limited to the *Compensated Flow High* value until the *Space Setpoint* is achieved. Once boost has terminated, compensated control begins and the valve is pulsed open or closed every ten seconds, the pulse length being one second per 1 degree error between the actual flow temperature and the calculated flow setpoint value for a maximum of ten seconds.

Boiler Compensation

Direct boiler compensation will fire the boiler(s) to maintain the calculated flow setpoint value. During the optimum start boost period, the flow temperature is limited to the *Compensated Flow High* value until the *Space Setpoint* is achieved. Once boost has terminated, compensated control begins and the flow temperature is maintained with a time and temperature hysteresis to prevent short cycling and provide stable conditions.

SINGLE BOILER COMPENSATION

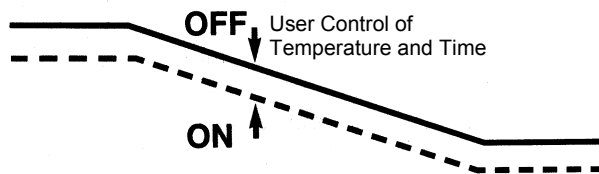

When setpoint is reached, the boiler will be switched off and not switched back on until the *Time Hysteresis* has elapsed and the *Temperature Hysteresis* has occurred. With direct boiler compensation, the *Boiler Flow Setpoint* is replaced by the calculated compensated flow setpoint.

Boiler/Valve Compensation

Combines valve and boiler compensation for maximum energy saving.

VALVE/BOILER COMPENSATION - TWO BOILER SEQUENCE CONTROL

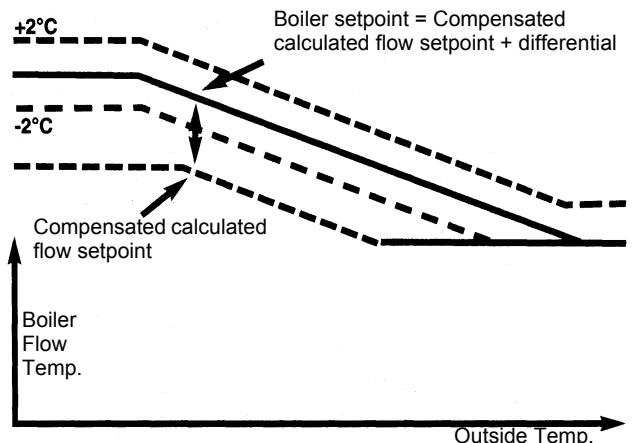

During the optimum start boost period, the flow temperature is limited to the *Compensated Flow High* value until the *Space Setpoint* is achieved. Once boost has terminated, compensated control begins and the compensated flow temperature is maintained by the mixing valve (see Valve Compensation operation), and the boiler(s) controlled at a higher temperature according to the set *Schedule Differential*, control being as described in Boiler Control section.

Night Setback

Setback will work with all three types of compensation where the compensated flow temperature will be reduced by the *Flow Night Setback* value.

VALVE COMPENSATION - SETBACK PERIOD

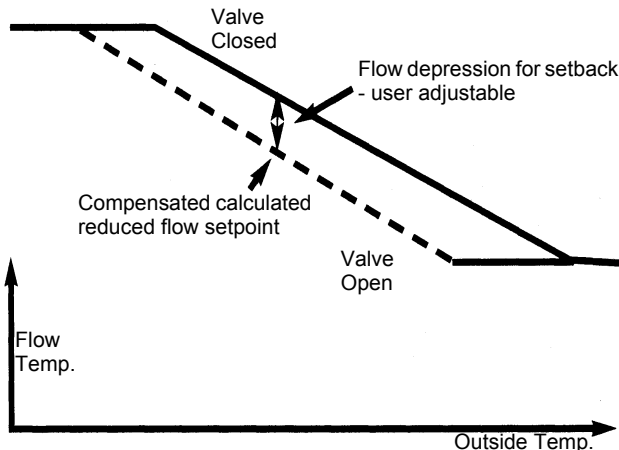

When enabled, setback control will commence at the end of occupation and continue until the next optimum start or occupation period. Alternatively, setback may be set to operate only when the space temperature has fallen below the *Space Night Setpoint* value.

Hot Water System

Three programmable time periods for each day of the week are available. The output can be operated independently or be boiler linked to switch the boiler(s) during an HWS time period. If the hot water system is demanding the boiler(s), the boiler(s) will switch on regardless of the demands of the optimiser or compensator and be controlled according to the dictates of the boiler control parameters. The HWS output can be made subject to frost protection. If enabled, the output will be on when any frost condition occurs.

In a HWS boiler linked mode, the boiler(s) will be switched off 15 minutes prior to the end of the HWS time period. This allows for overrun of a HWS primary pump in certain applications. However, if the heating is still within an occupation period, the boiler(s) will remain on. At the end of the HWS time period, the HWS output will switch off.

Pump/Valve Exercise

Automatically operates the heating pump and mixing valve once a month during prolonged periods of inactivity in order to reduce the possibility of sticking or corrosion.

If the pump or valve has not been used during the preceding twenty-eight days, the pump will operate and the valve will be opened automatically at midnight for a period of five minutes and then closed.

Holidays and Summer Heating Off

Up to twelve holiday periods may be preprogrammed and should be entered as start-stop dates.

If start-stop dates are entered as being the same, then that holiday period is ignored. During a holiday period, the whole system will be off with frost protection in operation.

The holiday begins on the first date entered, and will end on the stop date entered. The controller can also be put into holiday mode via the front panel switch or from a remote override switch. Holiday period number 12 is assigned as a summer heating off period. Within the start-stop dates entered the heating will be switched off, although the HWS output will still be operative unless overridden by any of the manual switches. Frost protection will apply during holiday period 12.

Clock/Calendar

A 365 day 24 hour clock is provided which is the basis for accurate switching operations. Leap years are automatically taken into account.

BST/GMT

Two programmable dates are provided to advance or retard the clock by one hour to take account of British Summer Time. The clock is automatically adjusted at 2.00am.

Alarms

The controller has an alarm LED that will be triggered by the following: Any of the sensor inputs are short or open circuit and/or out of range.

The boiler temperature is at least 10 degrees above the boiler high limit value.

The boiler temperature is below the boiler low value after one hour.

The compensated flow temperature is below the flow low value after one hour.

INSTALLATION



WARNING - ELECTRICAL SHOCK HAZARD. THIS CONTROLLER OPERATES FROM A 230Vac MAINS SUPPLY. ALWAYS ISOLATE THE MAINS SUPPLY FROM THE UNIT BEFORE REMOVING THE CONTROLLER FROM THE BACKPLATE.

Wall Mounting

The controller should be sited at eye level in a position free from excessive temperature variations and high humidity, which may affect its stable operation. The site should be a flat vertical wall, with sufficient space to run conduit to the top or bottom of the case. Allow at least 100mm space below the case.

Unpack the controller and open the protective cover.

Unscrew the single captive screwed pillar (accessible at the centre of the front panel) and unplug the wiring base unit from the controller.

Discard the panel mounting brackets. Secure the wiring base unit to the wall with four appropriate screws using the fixing holes provided (see back page for fixing detail illustration).

Knock out the appropriate 20mm cable entries and wire to the terminals in accordance with the wiring diagram for the chosen application. Take care to separate the input and output cabling to avoid introducing possible interference into the inputs.

Plug the controller into the wiring base and secure by screwing up the central captive screw pillar.

Panel Mounting

For panel mounting, a cut-out 186 x 137 +/- 1mm is required with at least 87mm clear space at the rear (see back page).

Separate the controller from its wiring base as described above.

Introduce the controller into the cut-out from the panel, taking care not to bend or damage the gold plated pins which project from the back of the controller. Whilst supporting the controller in position, attach the two panel mounting clips and tighten the controller against the panel.

WARNING - THIS PRODUCT CONTAINS A NICKEL METAL HYDRIDE BATTERY WHICH IS COMPLETELY SAFE WHILST IN NORMAL USE. THE BATTERY MUST BE DISPOSED OF IN AN AUTHORISED LANDFILL SITE.

WIRING

Mains Power Supply Wiring



WARNING - ELECTRICAL SHOCK HAZARD. THIS CONTROLLER OPERATES FROM A 230Vac MAINS SUPPLY. ALWAYS ISOLATE THE MAINS SUPPLY FROM THE UNIT BEFORE REMOVING THE CONTROLLER FROM THE BACKPLATE.

The controller requires a 230Vac 50Hz input connected to the power supply terminals. A direct clean earth must be provided to all controllers. This earth must not be used for other equipment.

Wire the Mains Supply to the appropriate terminals on the base plate. Ensure that a good earth is supplied to the earthing stud. Care should be taken to ensure that mains supplies are kept separate from all input wiring.

The earth on the controller is important and should be sourced directly from the supply.

General Wiring Precautions

WARNINGS -

ALL OUTPUTS FROM A CONTROLLER MUST USE A COMMON MAINS PHASE. DO NOT MIX MAINS PHASES ON A CONTROLLER. THIS IS REQUIRED TO PREVENT THE POSSIBILITY OF FLASHOVER BETWEEN DIFFERENT MAINS PHASES.

ALL OUTPUTS FROM A CONTROLLER MUST USE A COMMON VOLTAGE, I.E. 230Vac OR 24Vac. DO NOT MIX VOLTAGES ON A CONTROLLER. THIS IS REQUIRED TO PREVENT THE POSSIBILITY OF FLASHOVER FROM THE 230Vac TO THE 24Vac.

IF A 24Vac OUTPUT IS REQUIRED FROM A CONTROLLER PROVIDING ONLY 230Vac OUTPUTS, AN EXTERNAL RELAY MUST BE USED TO PROVIDE THE 24Vac OUTPUT.

IF A 230Vac OUTPUT IS REQUIRED FROM A CONTROLLER PROVIDING ONLY 24Vac OUTPUTS, AN EXTERNAL RELAY MUST BE USED TO PROVIDE THE 230Vac OUTPUT.

Cautions

Input and output wiring must never be mixed in the same cable or MICC, nor should they share the same conduit or cable tray, or be crossed within the controller. Avoid running input cables adjacent to power cables and if it is necessary to cross externally, then cross at right angles.

Screened wiring is mandatory for all inputs.

Screens should be earthed at controller only.

All temperature, voltage sensor and contact inputs must be screened with the screens connected separately to a common earth point. This earth point should be connected to the controller earth (0V terminal) by a single cable which should be as short as possible and not more than 150mm long.

IMPORTANT: Low voltage unscreened signal wiring must be run in a separate loom or trunk from any mains wiring and distanced far away from it (230Vac 450mm minimum, 415Vac 580mm minimum; both voltages are with respect to earth and a maximum current of 15A). For other voltage/currents refer to the IEE report titled 'Electro magnetic interference' September 1987 (ISBN 85296353X).

Wiring from controller to:	Maximum length for 1.5mm ² core unscreened cable	Maximum resistance per conductor
Sensors		
DRT (non-adjustable)	Screened only	25Ω
A701, A702, A703, A704	Screened only	25Ω
Remote Switch Unit		
04-03-109	Screened only	10Ω
Actuators		
ALM, ARM, AVUM, RM	100m	10Ω
	100m	5Ω
Relay Outputs		
i.e. Pump, boiler etc.	100m	5Ω
Relays, timeswitches, override contacts etc.	Screened Only	5Ω
Serial link		
(RS 232)	15m max. Screened RS 232 cable	

Notes:

1. Use one of the following screening options:

- Screened cable. Earth screen at controller end only
 - Mineral Insulated Copper Covered Cable (MICC). Earth sheath at controller end only.
2. Do not run low voltage (24V or less) wiring in the same harness as mains wiring in control panels.

Input Wiring

All input wiring must be run in screened twisted pair cable, (minimum size 7/0.2mm) with stranded tinned copper conductors covered with either aluminised tape with drain wire or close woven braid. Typical cable would be Belden type 9501 or RS 368-671 (aluminised tape), or RS 367-331 (close woven braid).

Plastic covered MICC cable is acceptable if precautions are taken to ensure the outer copper sheathing is only earthed at the controller earth stud. If it is necessary to extend the MICC, screened cable as above must be used, ensuring the screen is maintained without earthing the screen/MICC copper sheathing at the junction. Field termination will normally require the use of plastic conduit fittings, to prevent incorrect earthing of the screen.

When the controller is panel mounted, the screens must be maintained within the panel and the screen only earthed at the controller earthing stud.

Input wiring must enter the controller mounting base on the left hand side when viewed from the front.

Output Wiring

Output wiring must be sized in accordance with the load and the cable run. It must enter the controller mounting base on the right hand side when viewed from the front.

COMMISSIONING



WARNING - ELECTRICAL SHOCK HAZARD. THIS CONTROLLER OPERATES FROM A 230V_{ac} MAINS SUPPLY. ALWAYS ISOLATE THE MAINS SUPPLY FROM THE UNIT BEFORE REMOVING THE CONTROLLER FROM THE BACKPLATE.

To commission the system it is necessary to complete all normal installation and wiring checks, in particular checking the correct connection of the sensors.

A speed clock facility is incorporated which runs the clock at 20 times its normal operating speed. This allows the operation of the system to be checked over a short time period. To operate the speed clock, enter a pass number of 402 and Enable.

When completed, the speed clock MUST be disabled.

COLD START

Upon first powering up the controller, it is necessary to perform a cold start to ensure the system correctly and automatically identifies all the sensors that are connected. To cold start the system, the EXIT and ENTER keys must be held down when the power is switched on to the controller.

This action self configures the controller to a particular application, dependant upon the temperature sensors connected.

There are 7 standard applications that are provided through the self configuring process:

- Scheme A - Optimiser only (See "SCHEME A" on Page 14)
- Scheme C - Valve compensator only - fixed time start (See "SCHEME C" on Page 16)
- Scheme D - Valve compensator only - fixed time start, boiler sequence control (See "SCHEME D" on Page 17)
- Scheme E - Boiler compensator - fixed time start, single boiler control (See "SCHEME E" on Page 18)
- Scheme F - Optimisation with boiler compensation, single boiler control (See "SCHEME F" on Page 19)
- Scheme G - Optimisation with valve compensation (See "SCHEME G" on Page 20)
- Scheme H - Optimisation with valve compensation and boiler sequence control (See "SCHEME H" on Page 21)

The controller will always pre-configure to one of the above systems when a cold start is performed and will operate according to the default settings. If other parameter settings or another application is required, manual adjustment of the program will then be required.

SETTINGS

Once configured, all that is necessary for most applications is to set the desired Space temperature, set the clock for current time and date and program the Heating and Hot Water occupancy periods. Additionally, up to 11 holiday periods may be pre-programmed together with a summer heating off period (Holiday no. 12).

Self adjustment of the Optimiser and Compensator will tune the controller to the system and building characteristics.

Default settings are provided in the System Parameters table and the actual settings can be changed using the SET position on the front panel switch to access the menus.

Passnumber protection is required to change the system menus and reset the alarms. The pass number is 112.

All the system values may be viewed without entering a passnumber.

DC1100 SYSTEM PARAMETERS

Parameter	Default	Range	Description
Space Setpoint	20°C	5°C - 50°C	The desired temperature for the controlled space.
Current Time	12:00	00:00 - 24:00	Time of day. Format HH:MM.
Current Day	Mon	Mon - Sun	Day of the week. Format Mon, Tue, etc.
Current Date	1 Jan	1 Jan - 31 Dec	Date of the Month. Format DD MM.
Current Year	1997	Range 0000 - 9999	Year. Format YYYY.
BST Date	30 Mar	1 Jan - 31 Dec	Start of British Summer Time. Format DD MM
GMT date	27 Oct	1 Jan - 31 Dec	End of British Summer Time. Format DD MM.
Heating Times	00:00 - 00:00	00:00 - 24:00	Periods of occupation. Up to three per day. Format HH:MM
Hot Water Times	00:00 - 00:00	00:00 - 24:00	Time periods for the Hot Water channel. Up to three periods per day.
Holiday Dates	01-01 - 01-01	01-01 - 31-12	Twelve on - off dates. During the holiday dates, the optimiser and compensator will be disabled. Frost protection will still be enabled. The twelfth date will operate as the summer heating off period.
Optimum Stop	Enabled	Enabled - Disabled	Turns off the heating under certain conditions.
Day Economy	Enabled	Enabled - Disabled	Turns off heating if certain conditions are met.
Outside Frost	2°C	-10°C - 35°C	If outside temperature falls below the Outside Frost limit, the valve will be opened and the heating pump will switch on.
Space Frost	10°C	5°C - 35°C	If space temperature falls below the Space Frost limit, the valve will be controlled to the compensated flow high value and pump and boiler will switch on.
Boiler Return Frost	4°C	0°C - 60°C	If the return temperature falls below the boiler return frost limit, the valve will be controlled to the compensated flow high value and boiler and pump will switch on.
Compensation type	Valve only	Valve, Boiler Valve/Boiler	Determines the system compensation type.

DC1100 SYSTEM PARAMETERS (CONTINUED)

Parameter	Default	Range	Description
Schedule Difference	10°C	0°C - 30°C	Used for valve/boiler systems only. This value is used to determine when the boiler can be switched off. If the boiler temperature is greater than the required compensated flow temperature plus the schedule difference, then the boiler will switch off.
Self Adaption	Adaptive	Adaptive - Non-adaptive	If selected, the compensator will self learn.
Space Depression	3°C	0°C - 30°C	This will cause the subtraction from the calculated compensated flow temperature of x °C for every 1°C error in space temperature.
Pump Run On	15 mins, 0 min will disable	0 - 60 minutes	Pump overrun time period.
Flow Night Setback	20°C	0°C - 50°C	Compensated flow depression - this will cause the subtraction from the calculated compensated flow temperature of x °C.
Space Night Setpoint	16°C	0°C - 50°C	The space temperature below which night setback control operates.
Compensated Flow High	82°C	20°C - Boiler High Value	Maximum value of compensated flow temperature during compensation. Occurs when the outside temperature is at or below its low value. Also used to control the valve during frost protection and optimum start.
Outside Low	-1°C	-15°C - 50°C	Outside temperature to produce compensated flow high.
Compensated Flow Low	35°C	0°C - 120°C	Minimum value of compensated flow temperature during compensation.
Outside High	15°C	0°C - 35°C	Outside temperature to produce compensated flow low.
Number of Boilers	1	1 - 2	Sets the range to be controlled.
Boiler time hysteresis	5 mins	1 min - 30 mins	Used in single boiler, boiler compensation, or valve/boiler systems. This parameter will determine the minimum period of time that will elapse before the boiler can switch ON having already been switched OFF.
Boiler temp hysteresis	5°C	2°C - 20°C	Used in single boiler, boiler compensation, or valve/boiler systems. This parameter will determine the minimum temperature drop that must occur before the boiler can switch ON having already been switched OFF.

DC1100 SYSTEM PARAMETERS (CONTINUED)

Parameter	Default	Range	Description
Rotate Boilers	Enabled	Enabled - Disabled	Lead boiler is alternated weekly.
Upper Lag	5 mins	1 min - 20 mins	Time elapsed, before the second boiler is sequenced OFF, since the boiler flow temperature exceeds the +2°C band. The first boiler is sequenced OFF immediately the +2°C band is exceeded.
Lower Lag	5 mins	1 min - 20 mins	Time elapsed, before a boiler is sequenced ON, since the boiler flow temperature went below the -2°C band.
Boiler Setpoint	82°C	20°C - 100°C	Centre temperature at which boiler will be controlled within a ±2°C band.
Boiler Low	10°C	10°C - 50°C	Boiler low alarm value.
Boiler High	90°C	(Boiler Flow High Value) 120°C	Boiler high alarm value. 10°C above this value, all boilers will be switched off. A hysteresis of 2°C then operates before boilers are allowed to fire.
HWS Link Option	Independent	Independent - Boiler linked	This will determine if the hot water channel is independent or boiler linked.
HWS Extension	Enabled	Enabled - Disabled	If enabled, the HWS output will be extended from the remote heating on switch.
HWS Frost Protection	Disabled	Enabled - Disabled	If enabled, the HWS output will operate under a frost condition.
Comms type	Modem link	Modem link - Direct link	Controller can be modem linked or direct linked.
Unit number	1	1 - 99	Each controller in a communications network will have a unique number. This number must be quoted during communications.
Transmit Alarms	Enabled	Enabled - Disabled	When a controller senses an alarm, it will report this information to the controlling station if this variable is enabled.
Telephone No.	-	0 - 9, 14 characters	This is the telephone number of the controlling station.

DC1100 SENSOR RESISTANCE CHART

Temp. °C	Resistance Ω	Temp. °C	Resistance Ω	Temp. °C	Resistance Ω
-20	331,020	28	26,107	76	3,743
-18	293,370	30	23,827	78	3,487
-16	260,370	32	21,768	80	3,251
-14	231,410	34	19,907	82	3,033
-12	205,960	36	18,223	84	2,831
-10	183,560	38	16,697	86	2,644
-8	163,820	40	15,314	88	2,472
-6	146,400	42	14,059	90	2,312
-4	131,000	44	12,919	92	2,164
-2	117,380	46	11,882	94	2,026
0	105,310	48	10,937	96	1,899
2	94,596	50	10,077	98	1,780
4	85,080	52	9,292	100	1,670
6	76,614	54	8,577	102	1,568
8	69,078	56	7,922	104	1,473
10	62,355	58	7,324	106	1,384
12	56,352	60	6,777	108	1,301
14	50,985	62	6,275	110	1,224
16	46,185	64	5,815	112	1,153
18	41,883	66	5,394	114	1,085
20	38,022	68	5,006	116	1,023
22	34,557	70	4,650	118	964
24	31,440	72	4,323	120	909
26	28,634	74	4,021		

DC1100 SYSTEM MENU

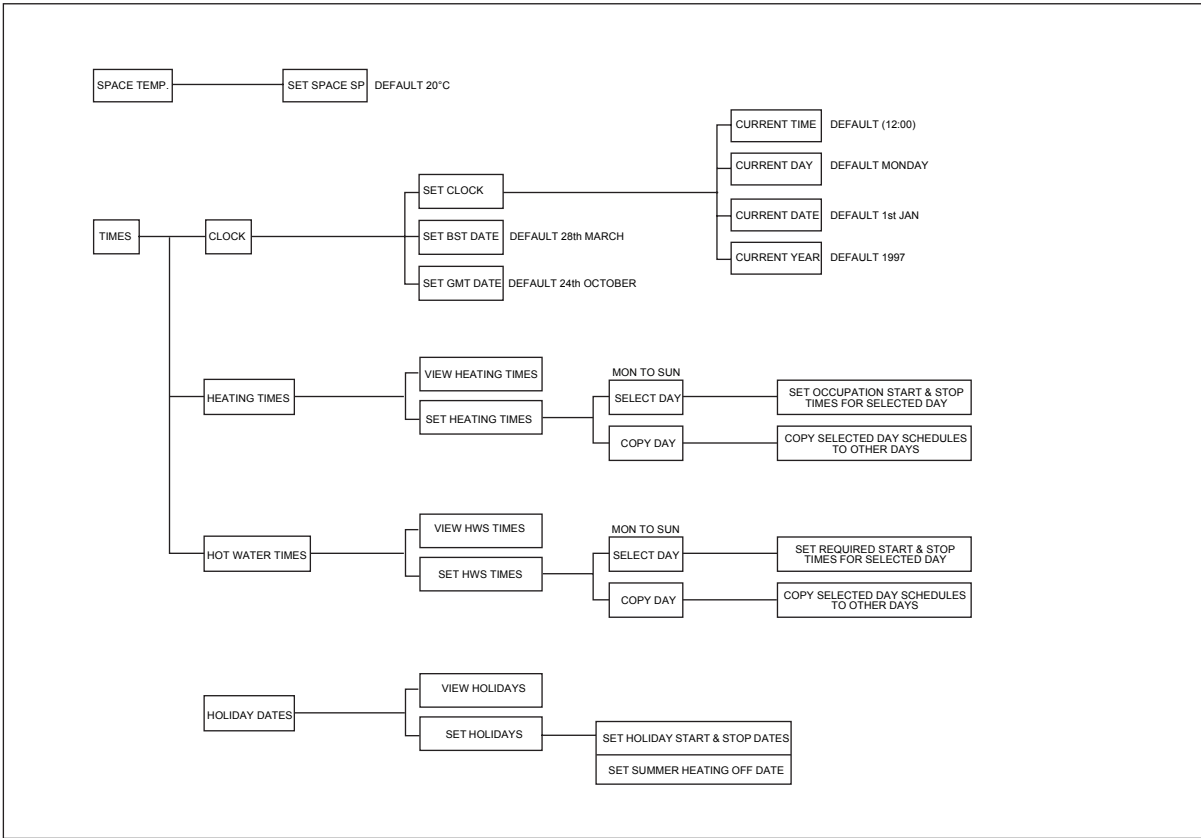

DC1100 SYSTEM MENU (CONTINUED)

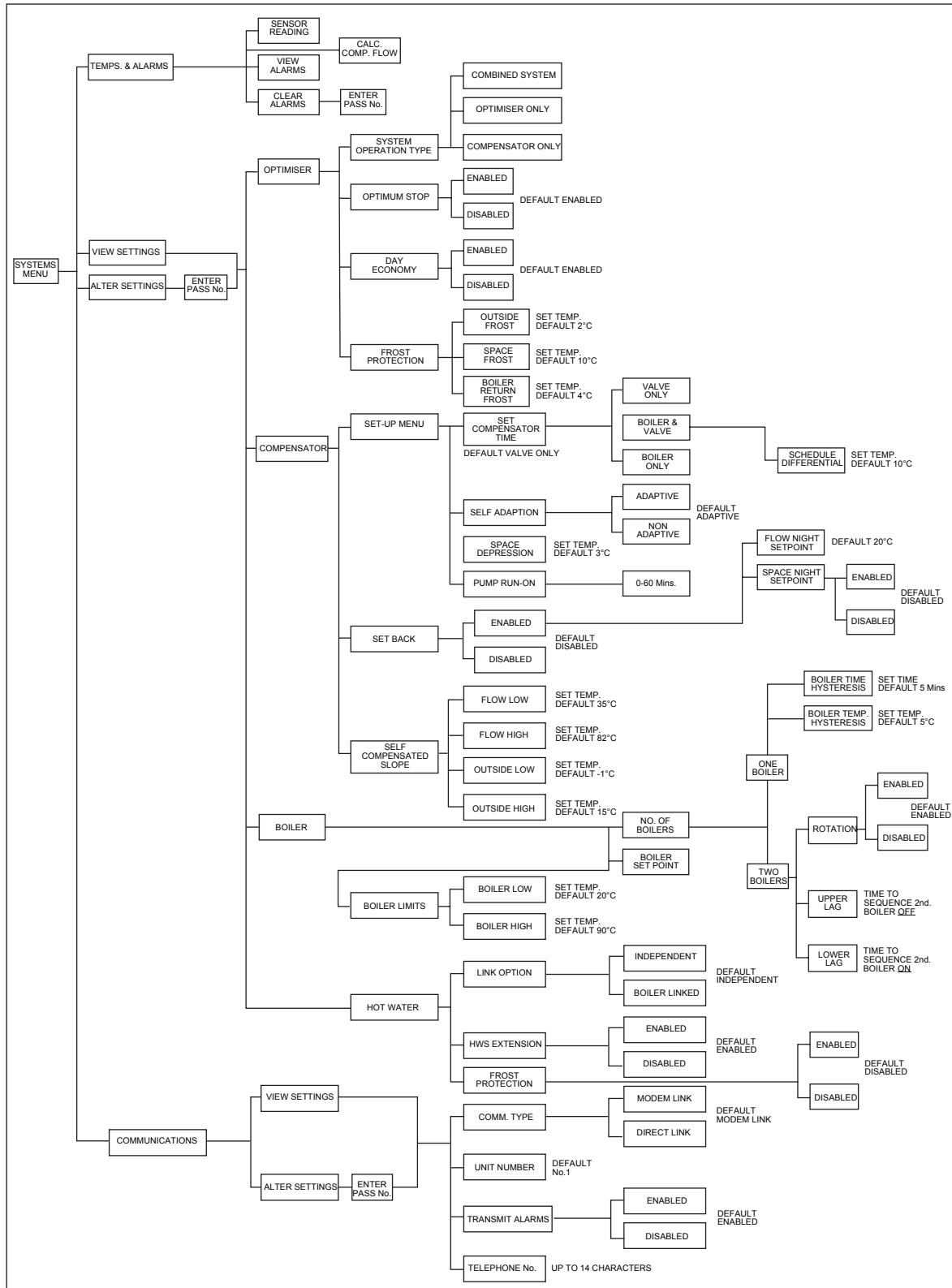

FRONT PANEL SWITCH

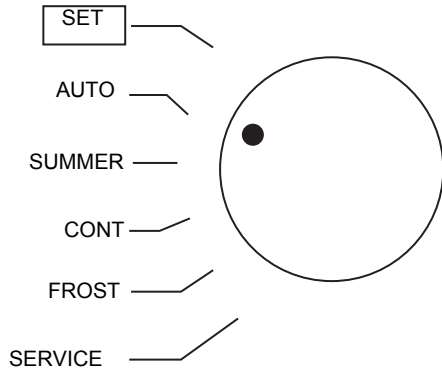

The front panel switch allows changes to the system operation without changing internal settings. This can be useful to quickly override the system operation when unusual circumstances occur.

SET

The SET position allows changes to temperature settings and times as well as a facility to change the other control setting, providing a pass number is entered.

AUTO

The heating and hot water are controlled by their clocks.

In this condition an optimised start and stop to the heating times is in operation and compensated control is also in action, subject to these controls being enabled.

The hot water is fully operational providing a timed output and if required, a link to switch the boiler on.

A full range of control routines are operative such as holidays, BST/GMT clock adjustments and full 7 day 3 periods per day time controls on both heating and hot water.

Frost protection routines are enabled outside of the heating periods.

SUMMER

The normal hot water controls are operating, but the heating controls are set to be off. Full frost protection of the heating system is in place, safeguarding the building.

Note: If the summer mode is manually selected during a heating time period and pump run-on is enabled, the boiler(s) will be switched off for the duration of pump run-on.

CONT

The heating is continuously ON, providing controlled temperatures. The HWS output is continuously ON.

FROST

The heating and hot water channels are switched OFF. Frost protection is maintained at all times.

SERVICE

The service mode will bring on Boiler No. 1, Boiler No. 2 (if selected), pump and HWS outputs and overrides all temperature control. This function will self cancel and the controller will revert to the AUTO condition after 2 hours.

CHANGING AND VIEWING SETTINGS

The four keys adjacent to the display are used to change settings within the controller. These are used when the selector switch is set to SET.

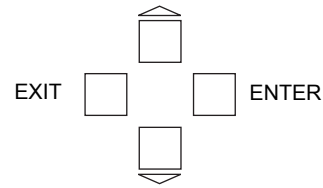

The ENTER key is used to confirm the option indicated in the display or to confirm the change to a value or setting. This key is also used to change the displayed temperature when the selector is not switched to SET.



The EXIT key is used to exit from a setting option without changing anything, even if changes have been attempted. This generally takes you back one step in the menu.



The UP key is used to either move the selection arrows up the display or to increase a displayed value.



The DOWN key is used to either move the selection arrows down the display or to decrease a displayed value.



DISPLAY

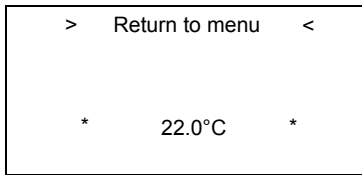
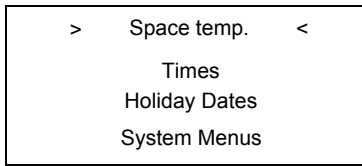
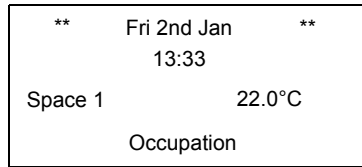

When the selector switch is set in the AUTO position, it indicates:

- current date
- current time
- one of the system temperatures
- the current control action

Note: The displayed temperature can be changed by pressing the ENTER key.

When the selector switch is in the SET position, it indicates a series of options for either changing or viewing.

The UP and DOWN keys move the arrows to the selection.

Pressing the ENTER key selects the item.

If the option selected requires a change to the value of a number, this can be achieved by pressing the UP or DOWN keys.

The arrows indicate the next action when the ENTER key is pressed. ENTER also confirms the new value.

If the EXIT key is pressed, even though the value may have been changed, the system returns to the menu, leaving the original value set in the controller.

DC1100 CONNECTION DIAGRAM

WARNINGS - ELECTRICAL SHOCK HAZARD

ALL OUTPUTS FROM A CONTROLLER MUST USE A COMMON MAINS PHASE. DO NOT MIX MAINS PHASES ON A CONTROLLER. THIS IS REQUIRED TO PREVENT THE POSSIBILITY OF FLASHOVER BETWEEN DIFFERENT MAINS PHASES.

ALL OUTPUTS FROM A CONTROLLER MUST USE A COMMON VOLTAGE, I.E. 230Vac OR 24Vac. DO NOT MIX VOLTAGES ON A CONTROLLER. THIS IS REQUIRED TO PREVENT THE POSSIBILITY OF FLASHOVER FROM THE 230Vac TO THE 24Vac.

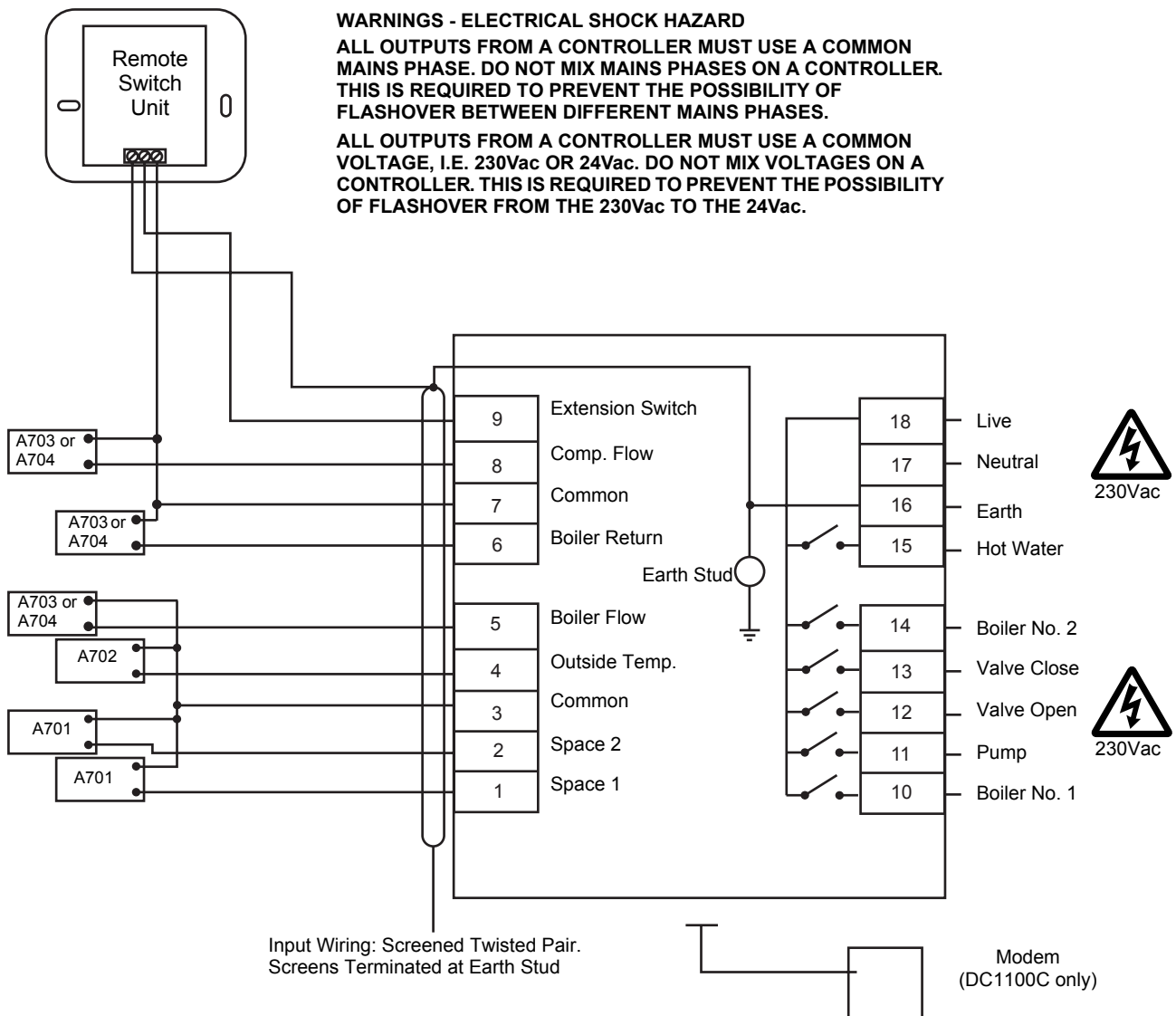

APPLICATION DETAIL

SCHEME A

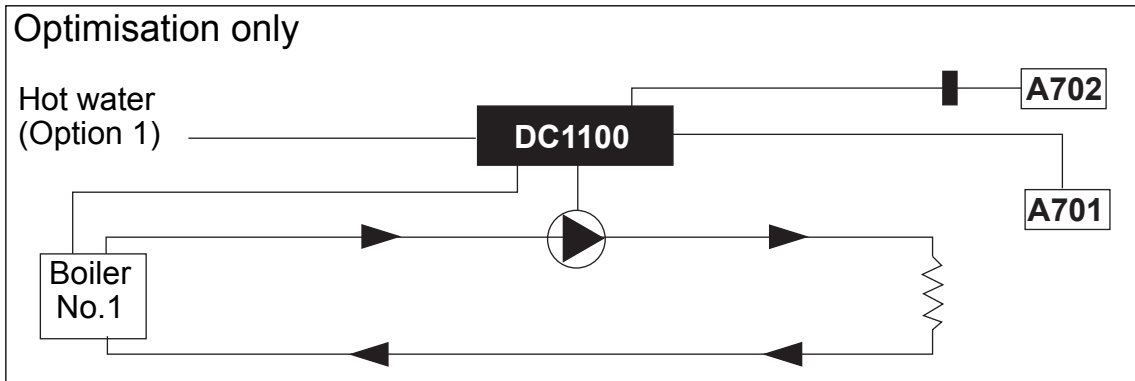

Equipment Schedule

- DC1100 controller
- A701 Space sensor
- A702 Outside sensor

Features

- Self adaptive optimum start
- Optimum stop
- Day economy
- Pump overrun
- 2 Stage frost protection
- Pump exercise routine
- Holiday scheduling
- BST/GMT auto clock change
- Summer/Winter selection
- Alarms

Options

- 1. Fixed time start of HWS - see hot water applications
- 2. Remote Auto/Summer/Heating On/Holiday selection switch
- 3. Additional Space sensor for averaging
- 4. Boiler return sensor for frost protection

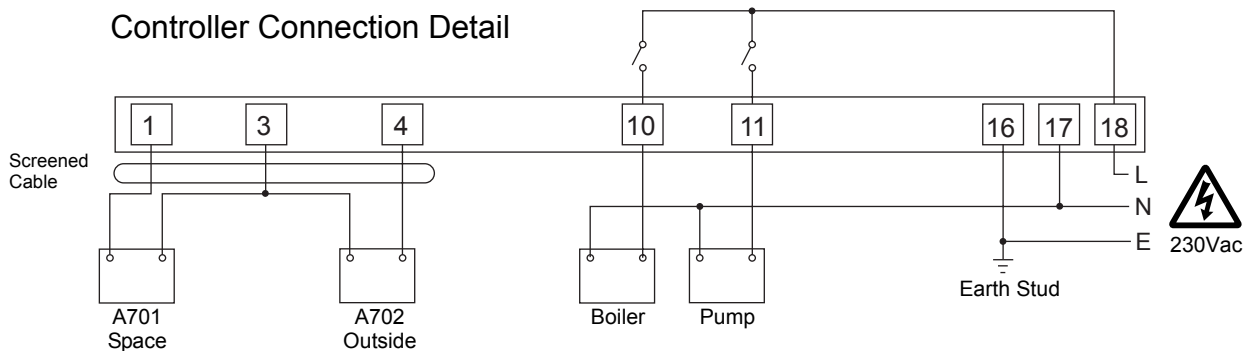

Sensor Screen Connections omitted for clarity

Note: Auxiliary relays/starters may be required if switching currents exceed 3A resistive, 1A inductive.

Important: For wiring specification see Page 4.

WARNING - OBSERVE WIRING PRECAUTIONS.

APPLICATION DETAIL (CONTINUED)

SCHEME B

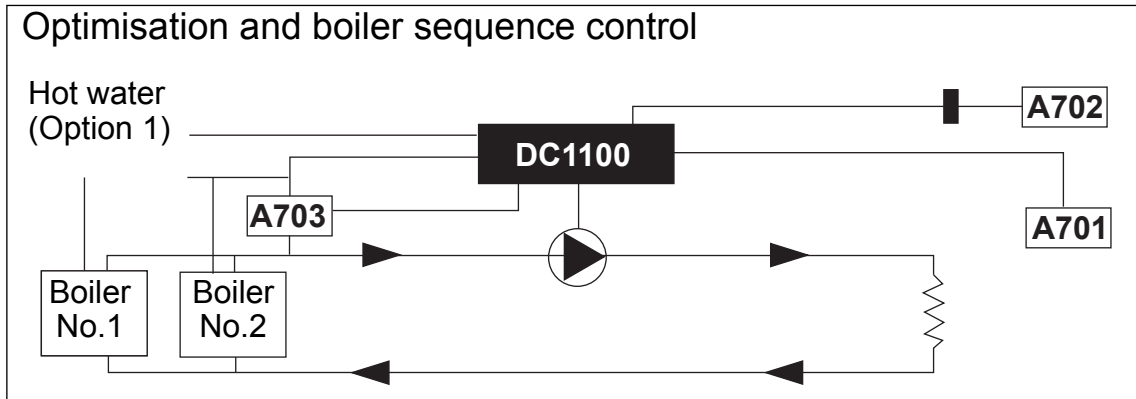

Equipment Schedule

- DC1100 controller
- A701 Space sensor
- A702 Outside sensor
- A703 Boiler flow sensor

Features

- Self adaptive optimum start
- Optimum stop
- Day economy
- Boiler sequence control
- Weekly boiler rotation
- Pump overrun
- 2 Stage frost protection
- Pump exercise routine
- Holiday scheduling
- BST/GMT auto clock change
- Summer/Winter selection
- Alarms

Options

1. Fixed time start of HWS - see hot water applications
2. Remote Auto/Summer/Heating On/Holiday selection switch
3. Additional Space sensor for averaging
4. Boiler return sensor for frost protection
5. A704 Strap on sensor available as an alternative to the A703 Immersion sensor

Controller Connection Detail

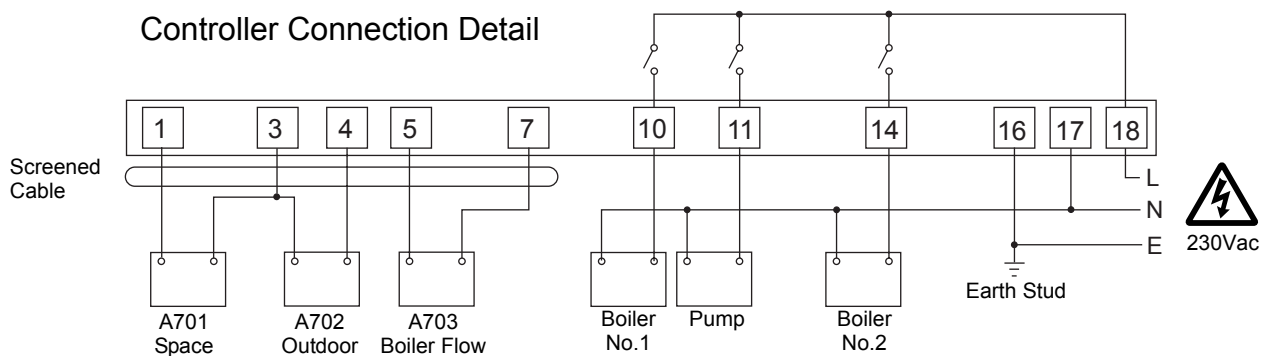

Sensor Screen Connections omitted for clarity

Note: Auxiliary relays/starters may be required if switching currents exceed 3A resistive, 1A inductive.

Important: For wiring specification see Page 4.

WARNING - OBSERVE WIRING PRECAUTIONS.

APPLICATION DETAIL (CONTINUED)

SCHEME C

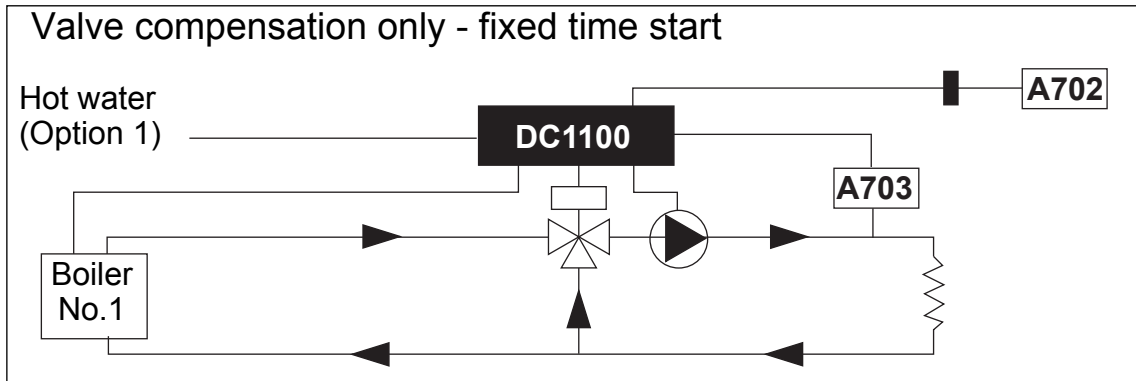

Equipment Schedule

- DC1100 controller
- A702 Outside sensor
- A703 Comp flow sensor
- 3 Port mixing valve (see valve details)

Features

- Fixed time start
- Valve compensation
- Night set back (flow)
- Pump overrun
- 1st Stage frost protection
- Valve/Pump exercise routine
- Holiday scheduling
- BST/GMT auto clock change
- Summer/Winter selection
- Alarms

Options

1. Fixed time start of HWS - see hot water applications
2. Remote Auto/Summer/Heating On/Holiday selection switch
3. A701 Space sensor to provide:
 - 2nd stage frost protection
 - Night set back (space)
 - Self adaptive compensation
 - Adjustable space temp reset
4. Boiler return sensor for frost protection
5. A704 Strap on sensor available as an alternative to the A703 Immersion sensor

Controller Connection Detail

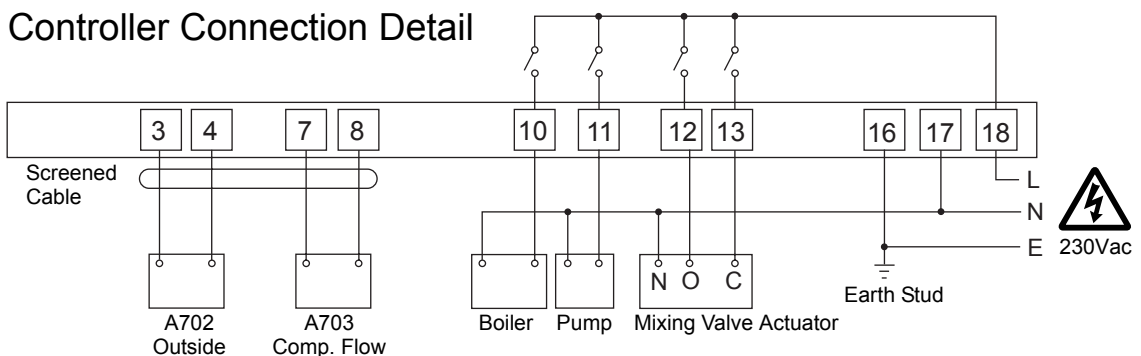

Sensor Screen Connections omitted for clarity

Note: Auxiliary relays/starters may be required if switching currents exceed 3A resistive, 1A inductive.

Important: For wiring specification see Page 4.

WARNING - OBSERVE WIRING PRECAUTIONS.

APPLICATION DETAIL (CONTINUED)

SCHEME D

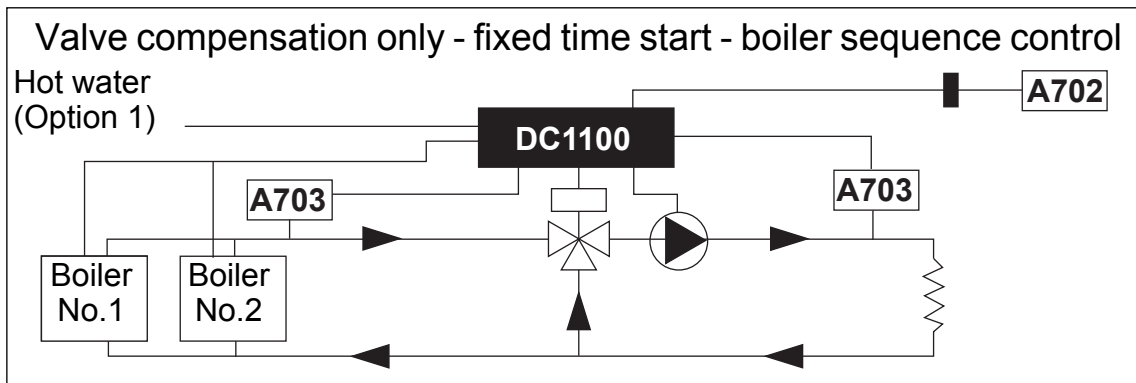

Equipment Schedule

- DC1100 controller
- A702 Outside sensor
- A703 Boiler flow sensor
- A703 Comp flow sensor
- 3 Port mixing valve (see valve details)

Features

- Fixed time start
- Boiler sequence control
- Weekly boiler rotation
- Valve compensation
- Night set back (flow)
- Pump overrun
- 1st stage frost protection
- Valve/Pump exercise routine
- Holiday scheduling
- BST/GMT auto clock change
- Summer/Winter selection
- Alarms

Options

1. Fixed time start of HWS - see hot water applications
2. Remote Auto/Summer/Heating On/Holiday selection switch
3. A701 Space sensor to provide:
 - 2nd stage frost protection
 - Night set back (space)
 - Self adaptive compensation
 - Adjustable space temp reset
4. Boiler return sensor for frost protection
5. A704 Strap on sensor available as an alternative to the A703 Immersion sensor

Controller Connection Detail

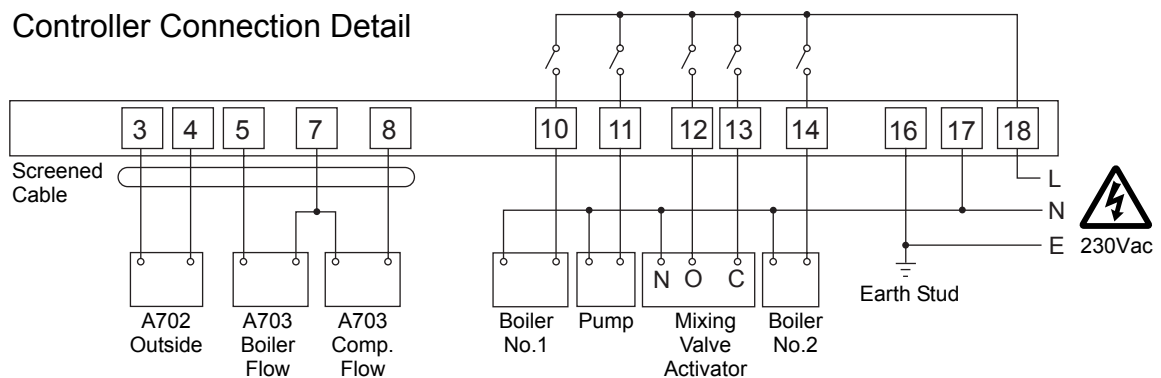

Note: Auxiliary relays/starters may be required if switching currents exceed 3A resistive, 1A inductive.

Important: For wiring specification see Page 4.

WARNING - OBSERVE WIRING PRECAUTIONS.

APPLICATION DETAIL (CONTINUED)

SCHEME E

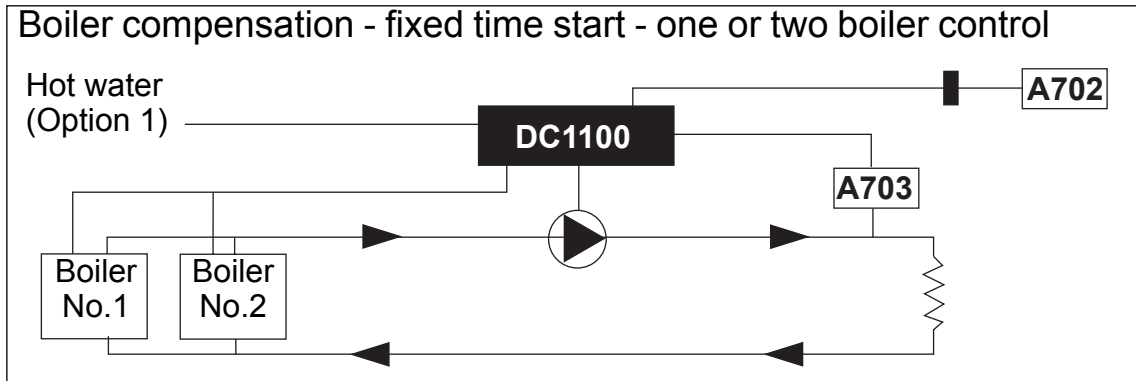

Equipment Schedule

- DC1100 controller
- A702 Outside sensor
- A703 Boiler flow sensor

Features

- Fixed time start
- Boiler sequence control
- Weekly boiler rotation
- Direct boiler compensation
- Night set back (flow)
- Pump overrun
- 1st stage frost protection
- Pump exercise routine
- Holiday scheduling
- BST/GMT auto clock change
- Summer/Winter selection
- Alarms

Options

1. Fixed time start of HWS - see hot water applications
2. Remote Auto/Summer/Heating On/Holiday selection switch
3. A701 Space sensor to provide:
 - 2nd stage frost protection
 - Night set back (space)
 - Self adaptive compensation
 - Adjustable space temp reset
4. Boiler return sensor for frost protection
5. A704 Strap on sensor available as an alternative to the A703 Immersion sensor
6. Manual selection for two boilers if required

Controller Connection Detail

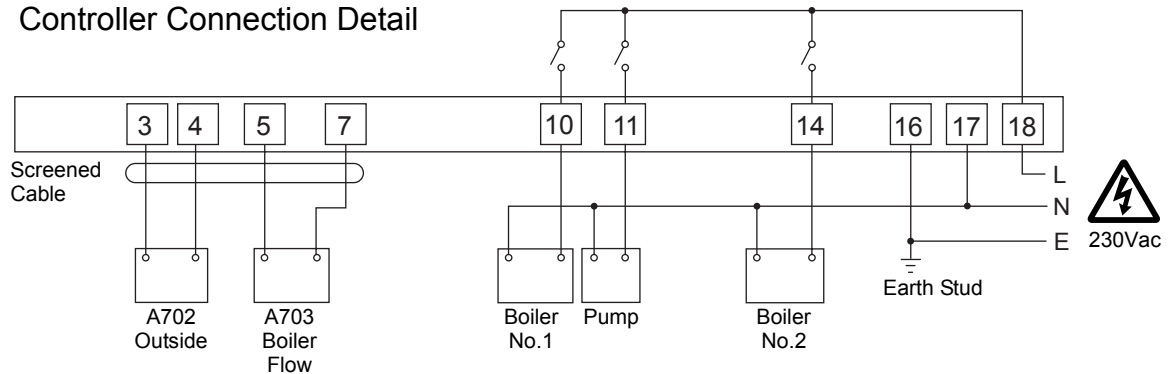

Sensor Screen Connections omitted for clarity

Note: Auxiliary relays/starters may be required if switching currents exceed 3A resistive, 1A inductive.

Important: For wiring specification see Page 4.

WARNING - OBSERVE WIRING PRECAUTIONS.

APPLICATION DETAIL (CONTINUED)

SCHEME F

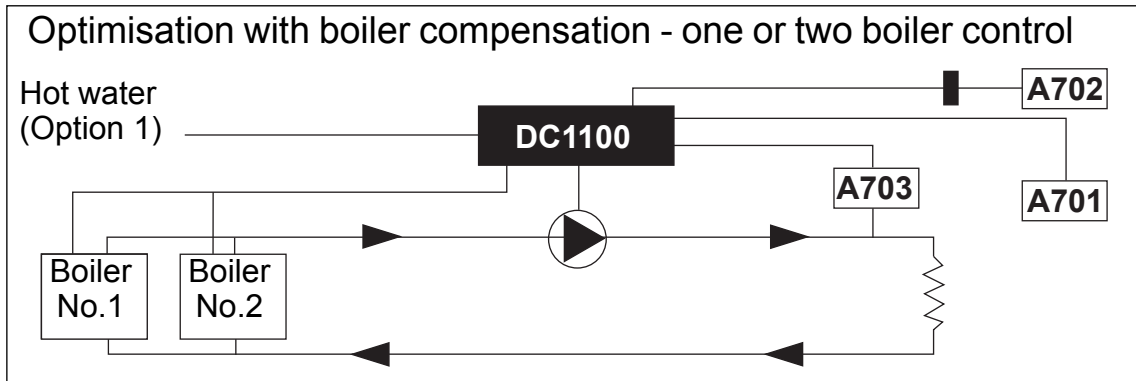

Equipment Schedule

- DC1100 controller
- A701 Space sensor
- A702 Outside sensor
- A703 Boiler flow sensor

Features

- Self adaptive optimum start
- Optimum stop
- Day economy
- Boiler sequence control
- Weekly boiler rotation
- Direct boiler compensation
- Adjustable space temperature reset
- Night set back options
- Pump overrun
- 2 Stage frost protection
- Pump exercise routine
- Holiday scheduling
- BST/GMT auto clock change
- Summer/Winter selection
- Alarms

Options

1. Fixed time start of HWS - see hot water applications
2. Remote Auto/Summer/Heating On/Holiday selection switch
3. Additional space sensor for averaging
4. Boiler return sensor for frost protection
5. A704 Strap on sensor available as an alternative to the A703 Immersion sensor
6. Manual selection for two boilers if required

Controller Connection Detail

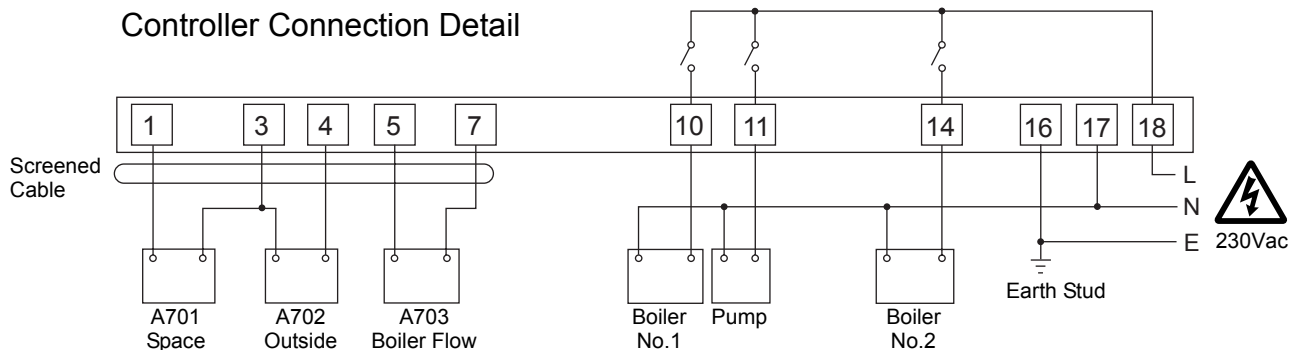

Sensor Screen Connections omitted for clarity

Note: Auxiliary relays/starters may be required if switching currents exceed 3A resistive, 1A inductive.

Important: For wiring specification see Page 4.

WARNING - OBSERVE WIRING PRECAUTIONS.

APPLICATION DETAIL (CONTINUED)

SCHEME G

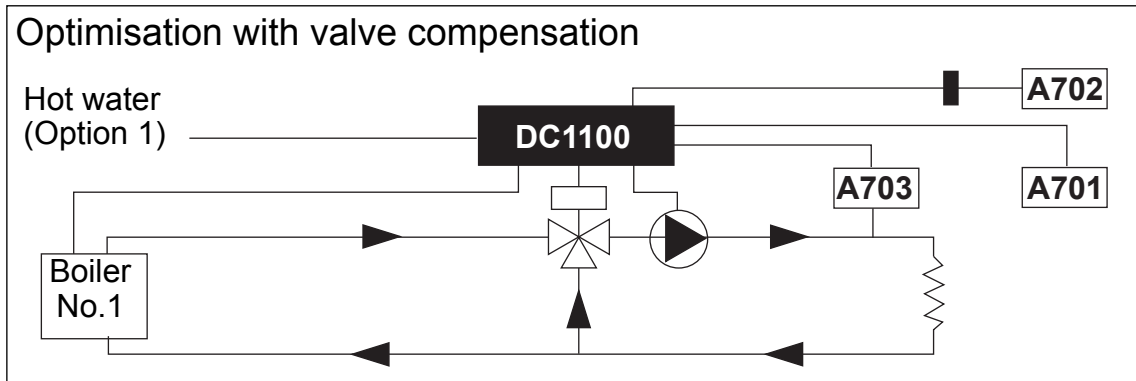

Equipment Schedule

- DC1100 controller
- A701 Space sensor
- A702 Outside sensor
- A703 Comp flow sensor
- 3 Port mixing valve (see valve details)

Features

- Self adaptive optimum start
- Optimum stop
- Day economy
- Valve compensation
- Adjustable space temperature reset
- Night set back options
- Pump overrun
- 2 Stage frost protection
- Valve/Pump exercise routine
- Holiday scheduling
- BST/GMT auto clock change
- Summer/Winter selection
- Alarms

Options

1. Fixed time start of HWS - see hot water applications
2. Remote Auto/Summer/Heating On/Holiday selection switch
3. Additional space sensor for averaging
4. Boiler return sensor for frost protection
5. A704 Strap on sensor available as an alternative to the A703 Immersion sensor

Controller Connection Detail

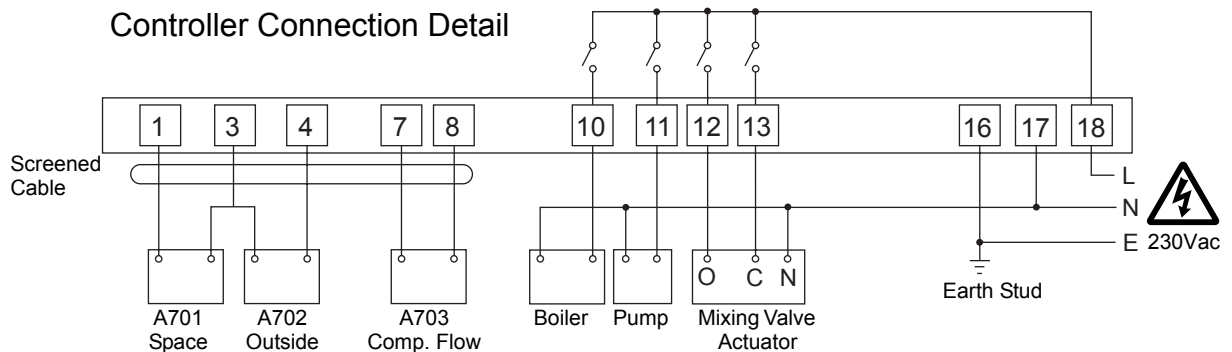

Sensor Screen Connections omitted for clarity

Note: Auxiliary relays/starters may be required if switching currents exceed 3A resistive, 1A inductive.

Important: For wiring specification see Page 4.

WARNING - OBSERVE WIRING PRECAUTIONS.

APPLICATION DETAIL (CONTINUED)

SCHEME H

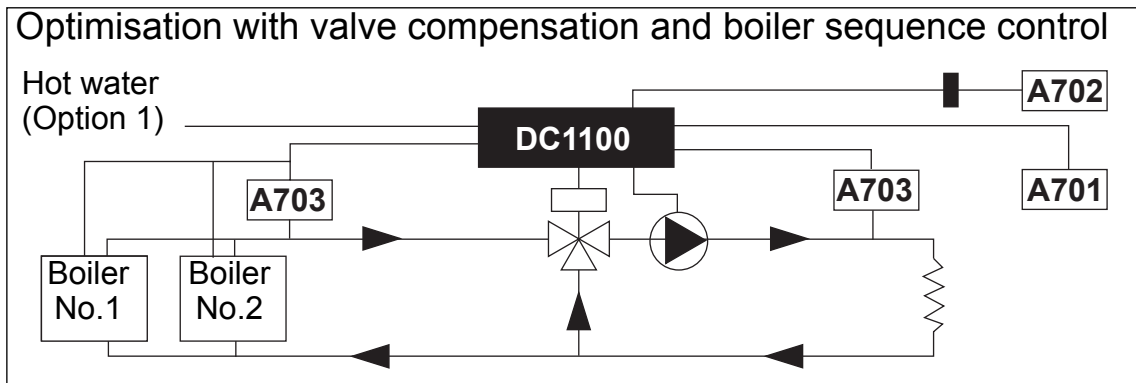

Equipment Schedule

- DC1100 controller
- A701 Space sensor
- A702 Outside sensor
- A703 Boiler flow sensor
- A703 Comp flow sensor
- 3 Port mixing valve (see valve details)

Features

- Self adaptive optimum start
- Optimum stop
- Day economy
- Boiler sequence control
- Weekly boiler rotation
- Valve compensation
- Adjustable space temperature reset
- Night set back options
- Pump overrun
- 2 stage frost protection
- Valve/Pump exercise routine
- Holiday scheduling
- BST/GMT auto clock change
- Summer/Winter Selection
- Alarms

Options

1. Fixed time start of HWS - see hot water applications
2. Remote Auto/Summer/Heating On/Holiday selection switch
3. Additional space sensor for averaging
4. Boiler return sensor for frost protection
5. A704 Strap on sensor available as an alternative to the A703 Immersion sensor

Controller Connection Detail

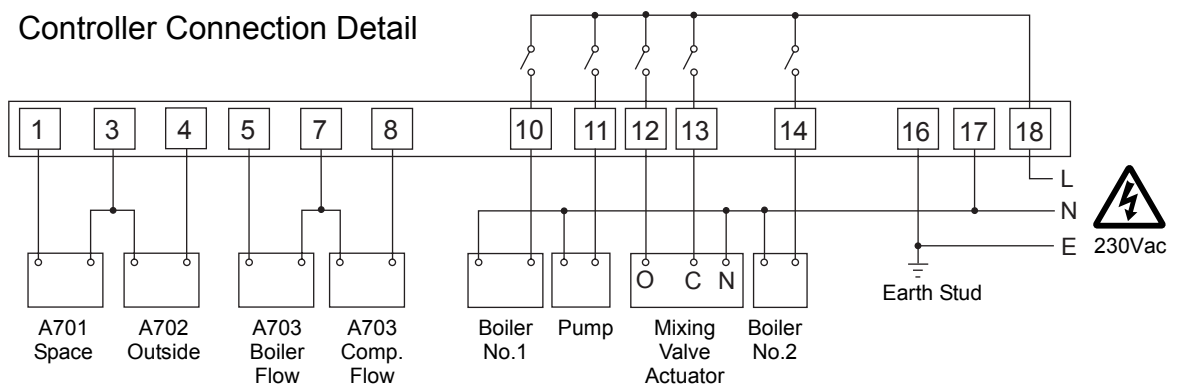

Sensor Screen Connections omitted for clarity

Note: Auxiliary relays/starters may be required if switching currents exceed 3A resistive, 1A inductive.

Important: For wiring specification see Page 4.

WARNING - OBSERVE WIRING PRECAUTIONS.

APPLICATION DETAIL (CONTINUED)

SCHEME I

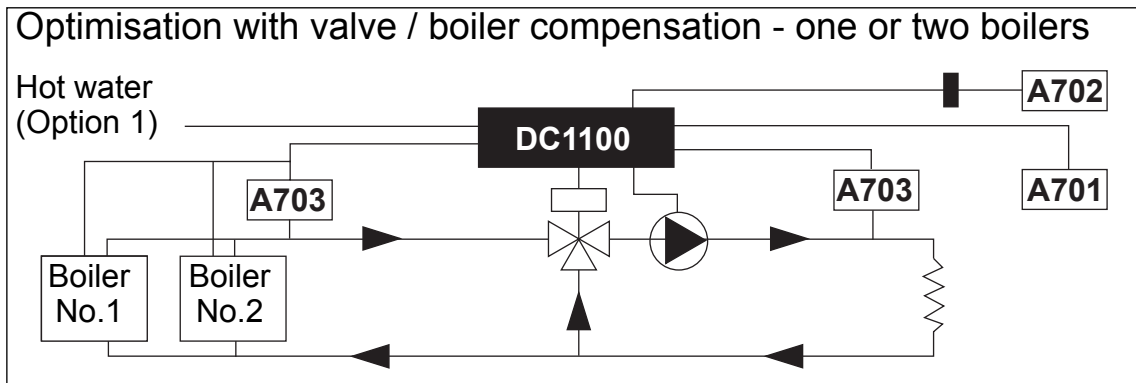

Equipment Schedule

- DC1100 controller
- A701 Space sensor
- A702 Outside sensor
- A703 Boiler flow sensor
- A703 Comp flow sensor
- 3 Port mixing valve (see valve details)

Features

- Self adaptive optimum start
- Optimum stop
- Day economy
- Boiler sequence control
- Weekly boiler rotation
- Combined valve/boiler compensation
- Adjustable schedule differential
- Adjustable space temperature reset
- Night set back options
- Pump overrun
- 2 stage frost protection
- Valve/Pump exercise routine
- Holiday scheduling
- BST/GMT auto clock change
- Summer/Winter selection
- Alarms

Options

1. Fixed time start of HWS - see hot water applications
2. Remote Auto/Summer/Heating On/Holiday selection switch
3. Additional space sensor for averaging
4. Boiler return sensor for frost protection
5. A704 Strap on sensor available as an alternative to the A703 Immersion sensor

Controller Connection Detail

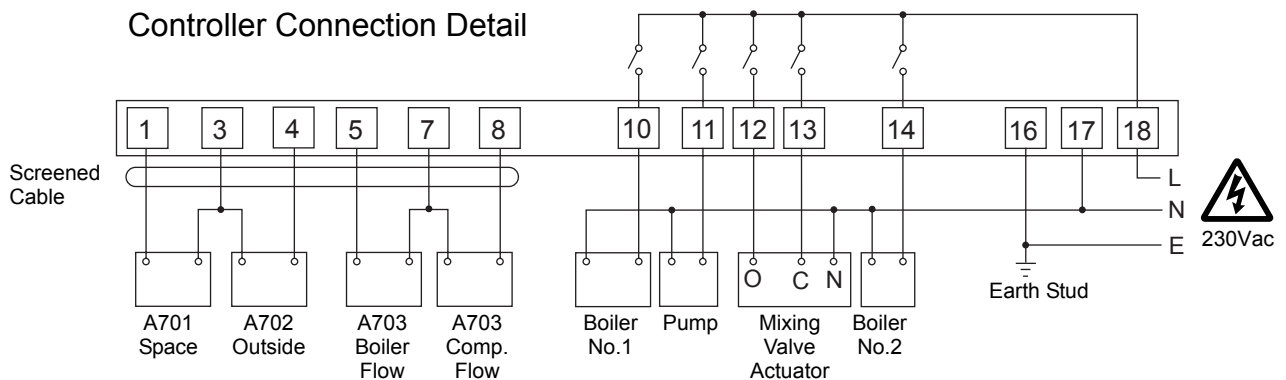

Sensor Screen Connections omitted for clarity

Note: Auxiliary relays/starters may be required if switching currents exceed 3A resistive, 1A inductive.

Important: For wiring specification see Page 4.

WARNING - OBSERVE WIRING PRECAUTIONS.

HOT WATER APPLICATIONS

The following diagrams show the application of the DC1100 to a variety of hot water controls.

Note: Auxiliary relays/starters may be required for switching currents in excess of 3A resistive or 1.5A inductive.

SCHEME K

TIME ONLY CONTROL OF HWS WATER HEATER

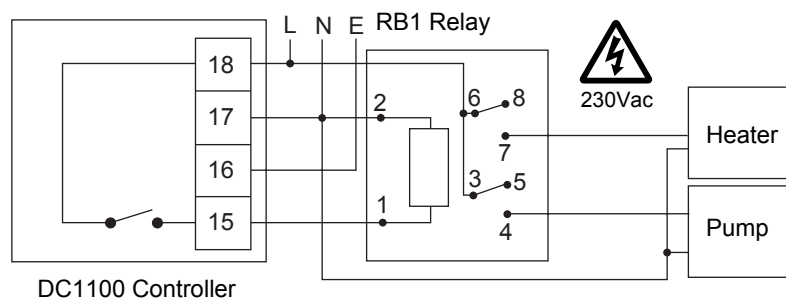
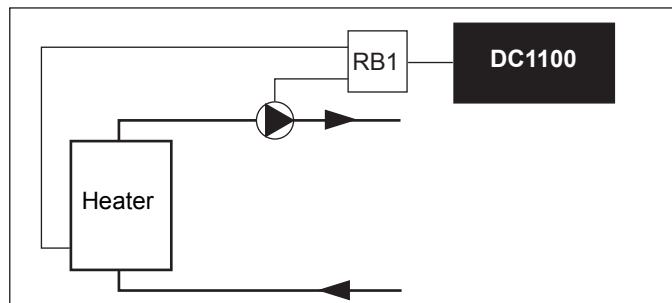

SCHEME L

TIME AND TEMPERATURE CONTROL OF CALORIFIER BY SWITCHING OF THE PRIMARY PUMP

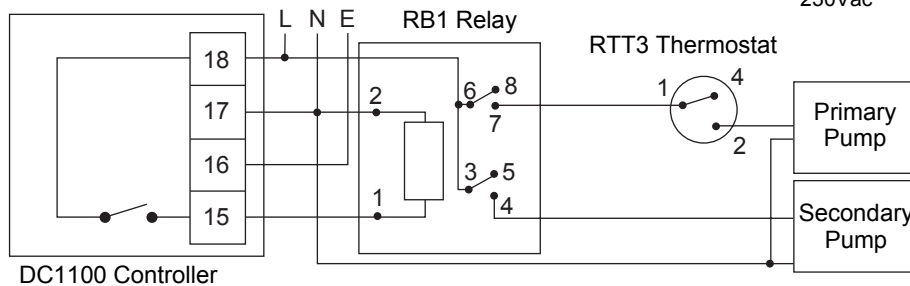
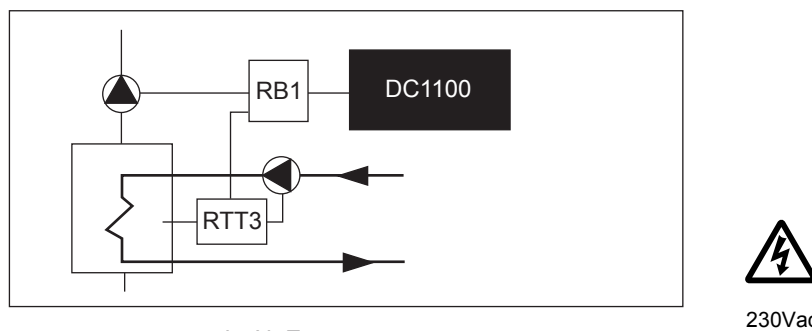

Hot water channel to be boiler linked in the settings - boiler compensation is overridden during HWS timed periods.

SCHEME M

TIME AND TEMPERATURE CONTROL OF CALORIFIER BY DIVERTING VALVE

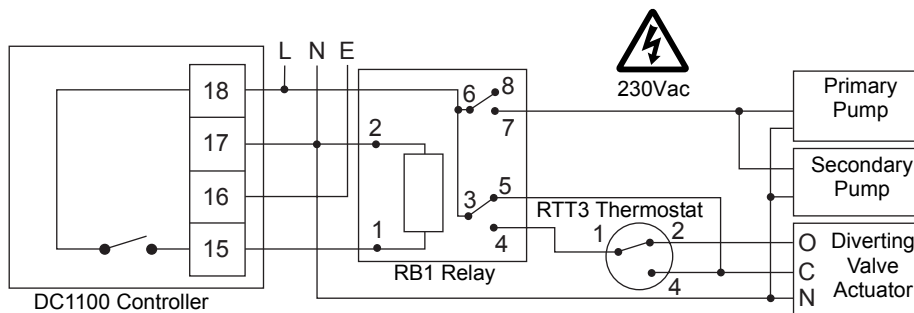
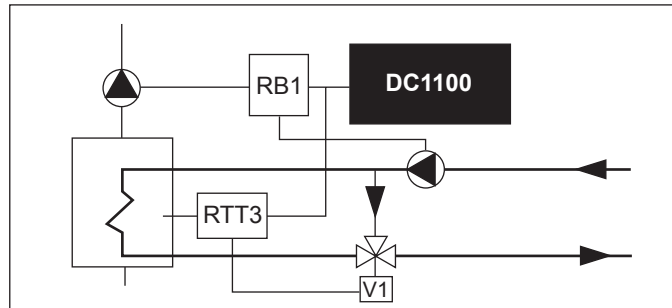

Hot water channel to be boiler linked in the settings - boiler compensation is overridden during HWS timed periods. The pumps operate continuously during timed period.

The boiler(s) will be switched off 15 minutes prior to the end of an HWS time period allowing dissipation of heat via the primary pump.

OUTSIDE AIR SENSORS SHARED BETWEEN CONTROLLERS

Note: A maximum of three controllers may be connected to a common outside air sensor.

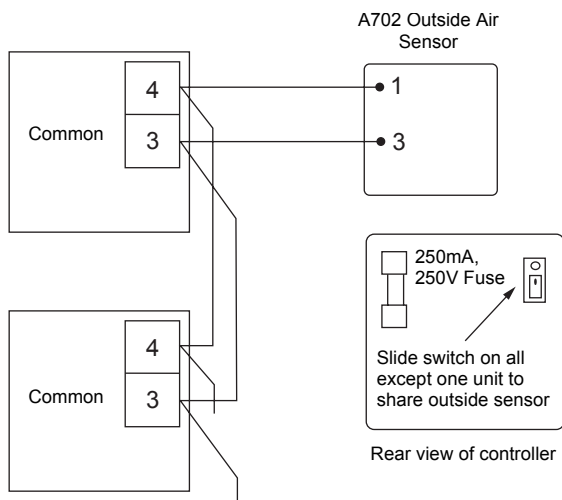

VALVE ACTUATOR OUTPUTS FOR 24V ACTUATOR

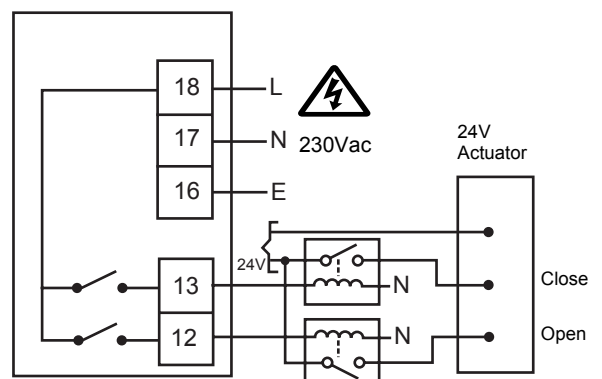

REMOTE SWITCH UNIT (PART NO. 04-03-109)

The Remote switch unit (see also DS 2.043) provides a means of overriding the normal control of the controller by switching the controller into one of four modes.

This is a repeat of the function on the controller front panel switch, but allows remote operation from some convenient location.

The override switch is operable only when the controller front panel switch is in the AUTO position.

EXTERNAL INPUTS

The functions can be operated from an external contact by switching a correct value resistor into a circuit similar to the switch unit.

AUTO

The controller remains in an AUTO condition unless overridden by it's own front panel switch.

SUMMER

The heating is off, but the hot water channel is operating to its set times. Frost protection is still enabled.

HEATING ON

Switches on the heating irrespective of the time periods. HWS will also be switched on if HWS Extension is enabled.

Will override pre-programmed Holidays and Summer heating off dates.

HOLIDAY

Switches both heating and hot water off, but retains the frost protection.

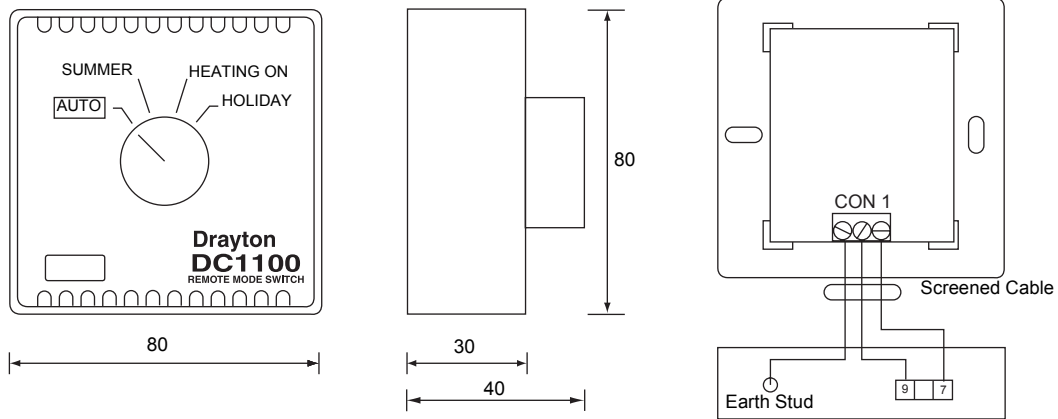

Dimensions in mm

REMOTE SWITCH UNIT DETAIL

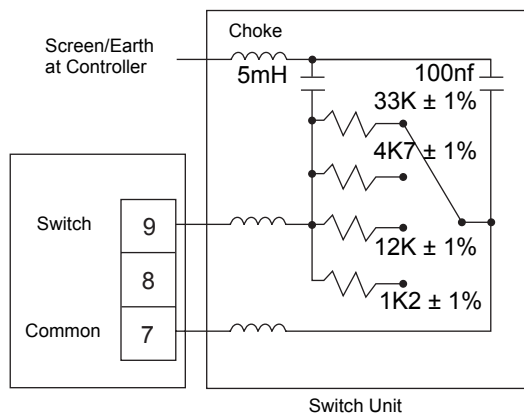

- Auto: 33K ± 1%
- Summer (HWS only): 4K7 ± 1%
- Heating On: 12K ± 1%
- Holiday (Off): 1K2 ± 1%

ALTERNATIVE SIMPLIFIED REMOTE INTERFACE

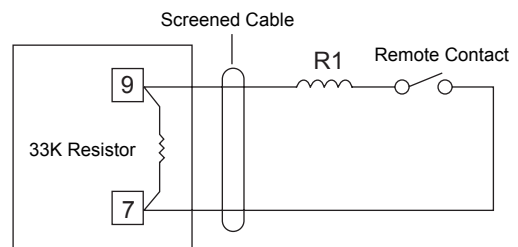

R1 Resistor Values for Remote Operator

Heating Extension:	18K
Summer:	5K6
Holiday/Frost:	1K2

The extension switch Input may be used for manually switched or electro mechanical inputs to switch the controller. This allows remote extension timers to be connected for instance.

Any of the conditions may be switched subject to the value of the resistor chosen. The de-energised value is 33K, which corresponds to the AUTO function. This in effect returns the controller to operate in its normal manner and removes the override.

MAINTENANCE

No user-serviceable parts are incorporated in the DC1100.

A periodic system and tuning check of the control system is recommended. Please contact your local Invensys office for details.

SENSOR TYPES

Space Temperature:	A701
Outside Air Temperature:	A702
Immersion Sensor with pocket:	A703
Pipe Surface Temperature:	A704

(Note: all sensors use the same element and are interchangeable to suit the application.)

Installation

Space sensors should be located away from draughts, direct heat, sunshine or cold outside walls. They should be mounted approximately 1.5 metres above floor level and wired through the backplate in accordance with the wiring data provided in this information and the current I.E.E. regulations. Sensors should be located in a representative area and not be inhibited from seeing the heat input.

Immersion sensors should be mounted in their previously installed pockets. The location of the sensor should be such that it is not in a dead leg and positioned to read a representative temperature.

Access to the wiring is via an M20 conduit connection.

Strap on sensors should be located in a relevant position. They are effective when a good physical contact is made between the sensing element in the case and the pipe or vessel. It is therefore important to locate a position where there is no lagging otherwise carefully remove a small section to allow the sensor to be positioned. For good thermal contact, the straps must be tight. Replacement of the lagging over the sensor aids accuracy.

Outdoor sensors should be sited on a north facing wall for single building applications. For zoning applications, the sensor should be subject to the weather conditions affecting the zone, but shielded from direct sunlight.

DIMENSION DIAGRAMS

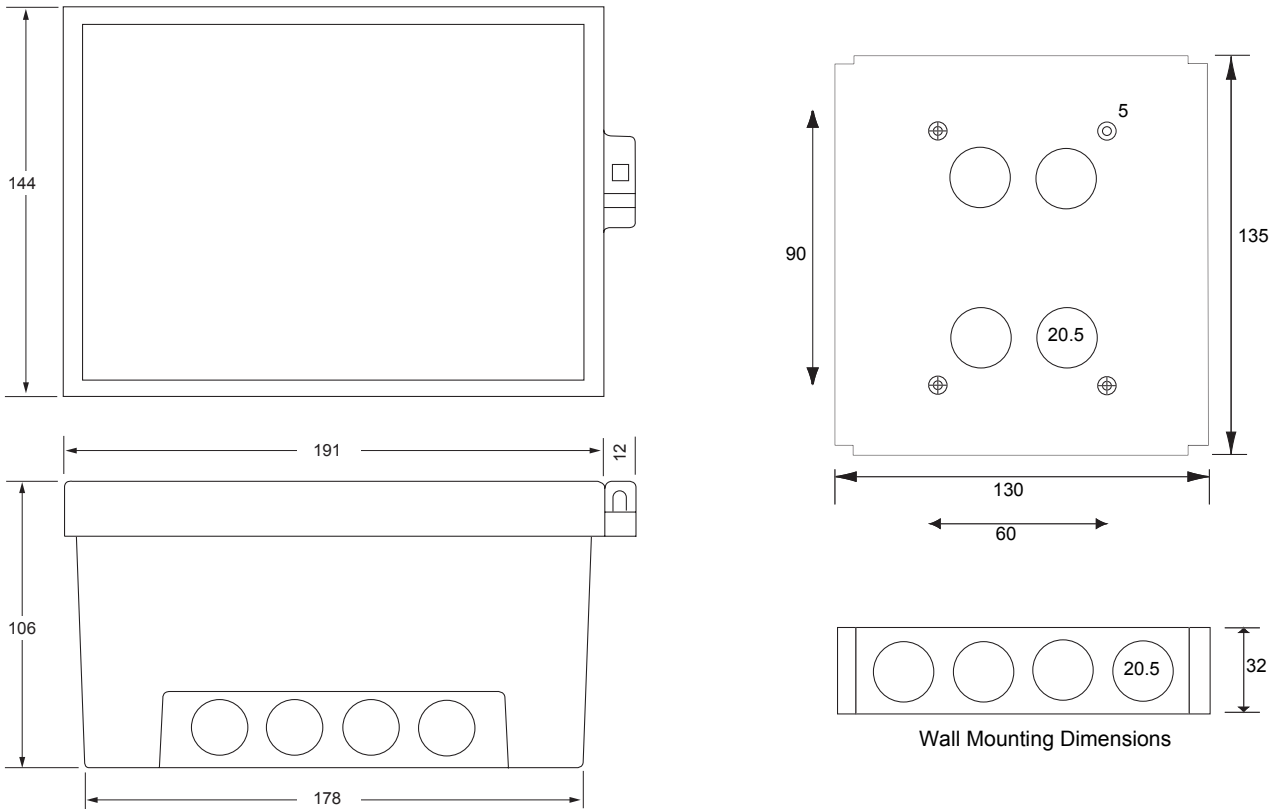

Dimensions in mm

Panel Cut-out details.
Allow 87mm depth.



Building Systems - UK
Invensys Energy Solutions
 Farnham Road
 Slough
 Berkshire SL1 4UH
 United Kingdom

Telephone +44 (0)1753 611000
 Facsimile +44 (0)1753 611001
 Web site www.ies.invensys.com



WARNINGS - ELECTRICAL SHOCK HAZARDS.

THIS CONTROLLER OPERATES FROM A 230Vac MAINS SUPPLY. ALWAYS ISOLATE THE MAINS SUPPLY FROM THE UNIT BEFORE REMOVING THE CONTROLLER FROM THE BACKPLATE.

ALL OUTPUTS FROM A CONTROLLER MUST USE A COMMON MAINS PHASE. DO NOT MIX MAINS PHASES ON A CONTROLLER. THIS IS REQUIRED TO PREVENT THE POSSIBILITY OF FLASHOVER BETWEEN DIFFERENT MAINS PHASES.

ALL OUTPUTS FROM A CONTROLLER MUST USE A COMMON VOLTAGE, I.E. 230Vac OR 24Vac. DO NOT MIX VOLTAGES ON A CONTROLLER. THIS IS REQUIRED TO PREVENT THE POSSIBILITY OF FLASHOVER FROM THE 230Vac TO THE 24Vac.

WARNING - THIS PRODUCT CONTAINS A NICKEL METAL HYDRIDE BATTERY WHICH IS COMPLETELY SAFE WHILST IN NORMAL USE. THE BATTERY MUST BE DISPOSED OF IN AN AUTHORISED LANDFILL SITE.

Cautions

- Input and output wiring must never be mixed in the same cable or MICC, nor should they share the same conduit or cable tray. Avoid running input cables adjacent to power cables and if it is necessary to cross externally, then cross at right angles.
- Do not apply any mains or other voltages until the wiring is complete and has been checked by a qualified technician.
- If any equipment covers have to be removed during the installation of this equipment, ensure that they are refitted after installation to comply with UL and CE safety requirements.
- Do not exceed maximum ambient temperature.
- Interference with parts under sealed covers invalidates guarantee.
- Design and performance of Invensys equipment is subject to improvement and therefore liable to alteration without notice.
- Information is given for guidance only and Invensys does not accept responsibility for the selection and installation of its products unless information has been given by the Company in writing relating to a specific application.
- A periodic system and tuning check of the control system is recommended. Please contact your local Invensys office for details.