

STG 120/2, 146/1, 146/2 Gas Burner



STG Gas Burner features:

- Energy saving and compatible with environmental requirements
- Quiet in operation
- Reliable and trouble-free
- Designed and approved in accordance with the European Standard EN 676
- Available for Natural Gas and LPG
- Industry standard components easily available
- Single stage operation
- Air snorkel available as optional extra
- Plug-in contact facilitates the installation
- All kW ratings are nett CV



For more information on all Nu-way products
please visit www.nu-way.co.uk

Burner Type		STG 120/2	STG 146/1	STG 146/2
Capacity	kW	14.5-50	23.5-65	41-133
Motor	V/Hz	240/50	240/50	240/50
	W/A (Fuse)	90/6	125/6	125/6
Start / Run Current	Amps	1.5 / 0.91	1.5 / 0.91	1.5 / 0.91
Control box		Landis & Staefa	Landis & Staefa	Landis & Staefa
Flame monitoring		Ionisation	Ionisation	Ionisation
Gross weight	kg	11	13	13
Volume	m ³	0.04	0.05	0.05

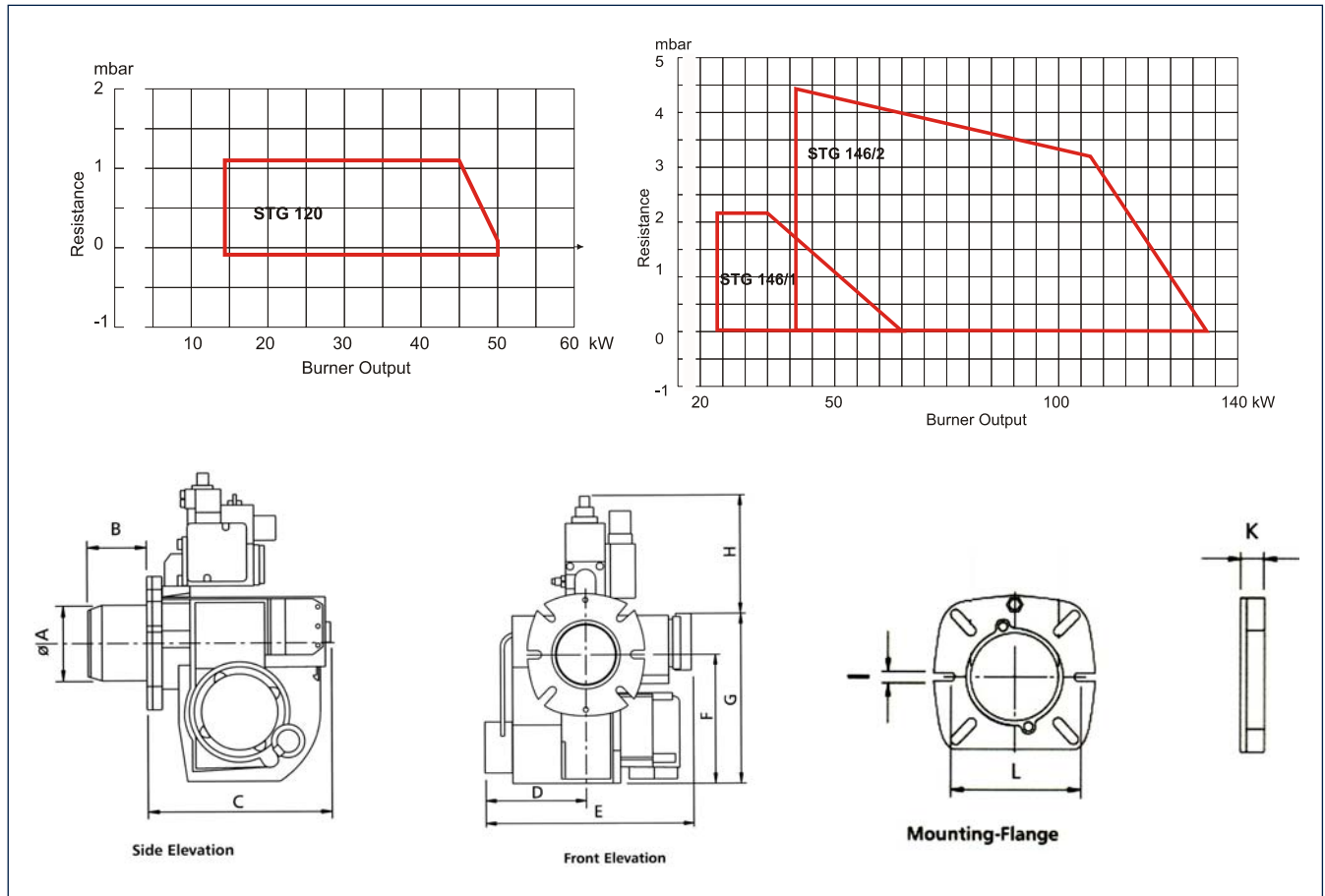

Burner	ϕA	B	C	D	E	F	G	H	I	K	L
STG 120/2	89	95	220	130	273	165	226	143	10.3	4	125-150
STG 146/1	89	95	244	139	290	192	253	202	10.3	4	125-150
STG 146/2	103	120	244	139	290	192	253	202	10.3	4	145-170

Enertech Limited, P O Box 1, Vines Lane
Droitwich, Worcestershire, WR9 8NA

tel: +44 (0) 1905 794331 • fax: +44 (0) 1905 794017
email: info@nu-way.co.uk • web: www.nu-way.co.uk

